



**MODEL 6745
BABY SCALE
Operation Manual**

8535-M074-O1 Rev A
04/05

CARDINAL SCALE MFG. CO.
PO BOX 151 • WEBB CITY, MO 64870
PH (417) 673-4631 • FAX (417) 673-5001
www.detectoscale.com



Printed in USA

TABLE OF CONTENTS

INTRODUCTION	1
QUICK START	1
INSTALLATION	2
Unpacking	2
Level Adjustment	2
Baby Tray Installation	3
Battery installation	4
Low Battery Indicator	5
Battery Status	5
Battery Charging	5
Placing the Scale	5
KEYPAD FUNCTIONS	6
ANNUNCIATORS	7
OPERATION	8
Basic Weighing operation	8
Operating Hints	8
CARE AND CLEANING	8
PRINTER OUTPUT	9
SERIAL DATA FORMATS	9
SETUP AND CALIBRATION	10
SETUP REVIEW	16
ERROR AND STATUS DISPLAYS	17
BEFORE YOU CALL SERVICE	17
PART IDENTIFICATION	18

SERIAL NUMBER _____
DATE OF PURCHASE _____
PURCHASED FROM _____

RETAIN THIS INFORMATION FOR FUTURE USE

PRECAUTIONS

Before using this instrument, read this manual and pay special attention to all "WARNING" symbols:



IMPORTANT



ELECTRICAL
WARNING



STATIC
SENSITIVE

INTRODUCTION

The Model 6745 Baby Scale is a 30 pound (15 kilogram) capacity, battery-operated baby scale housed in a painted steel enclosure. The scale is equipped with a removable baby tray and a color coded membrane keyboard. The Model 6745 has a number of special features that make it both easy to use and maintain. This manual contains information on the operation of the scale. Please take time to read the manual before using your new Model 6745.

FCC COMPLIANCE STATEMENT

WARNING! This equipment generates uses and can radiate radio frequency and if not installed and used in accordance with the instruction manual, may cause interference to radio communications. It has been tested and found to comply with the limits for a Class A computing device pursuant to Subpart J of Part 15 of FCC rules, which are designed to provide reasonable protection against such interference when operated in a commercial environment. Operation of this equipment in a residential area may cause interference in which case the user will be responsible to take whatever measures necessary to correct the interference.

You may find the booklet "How to Identify and Resolve Radio TV Interference Problems" prepared by the Federal Communications Commission helpful. It is available from the U.S. Government Printing Office, Washington, D.C. 20402, stock No. 001-000-00315-4.

All rights reserved. Reproduction or use, without expressed written permission, of editorial or pictorial content, in any manner, is prohibited. No patent liability is assumed with respect to the use of the information contained herein. While every precaution has been taken in the preparation of this manual, the Seller assumes no responsibility for errors or omissions. Neither is any liability assumed for damages resulting from use of the information contained herein. All instructions and diagrams have been checked for accuracy and ease of application; however, success and safety in working with tools depend to a great extent upon the individual accuracy, skill and caution. For this reason the Seller is not able to guarantee the result of any procedure contained herein. Nor can they assume responsibility for any damage to property or injury to persons occasioned from the procedures. Persons engaging the procedures do so entirely at their own risk.

QUICK START

Although it is recommended that you read this manual before attempting to operate the scale, this section is included to provide a condensed set of instructions on installing and using the scale. At a minimum, please make certain you read all of the caution and warning statements.

- Step 1 Install the baby tray by sliding the baby tray onto the weighbridge. Make sure the release knob "clicks" and locks the tray in place.
- Step 2 Turn the scale over on the tray, locate and remove the battery access cover on the bottom of the scale. Install six (6) "C" size batteries and then replace the cover.
- Step 3 Turn the scale over to the normal operating position.
- Step 4 Press the **ON** key to turn the scale on. If desired, place a blanket or pad on the baby tray and press the **ZERO** key to reset the weight display to zero.
- Step 5 Place the baby on the scale. Wait a few seconds for the weight to display and then read the baby's weight. Press the **UNITS** key to toggle between Pounds & Ounces and Kilograms weighing units.
- Step 6 Remove the baby from the scale. Press the **OFF** key to turn the scale off.

INSTALLATION

Unpacking

Begin the installation by removing your new Model 6745 Baby Scale from the shipping carton. Examine the scale and baby tray for any damage that may have taken place during shipment. If you find evidence of shipping damage, the shipping company should be contacted at once. It is a good idea to keep the scale shipping carton and packing material for later use should storage or transport of the scale become necessary.

Level Adjustment

Check to make certain the scale is level. The level indicator is located in the center of the weighbridge under the baby tray. Remove the baby tray and observe the level bubble (see Figure No. 1). If the scale is not level (the bubble will not be centered), loosen the locking nut on all four (4) mounting feet (see Figure No. 2) and adjust them as required to center the bubble and attain a level scale. Once a level condition has been obtained, lock the mounting feet in place by tightening the adjustment nuts against the bottom of the scale.

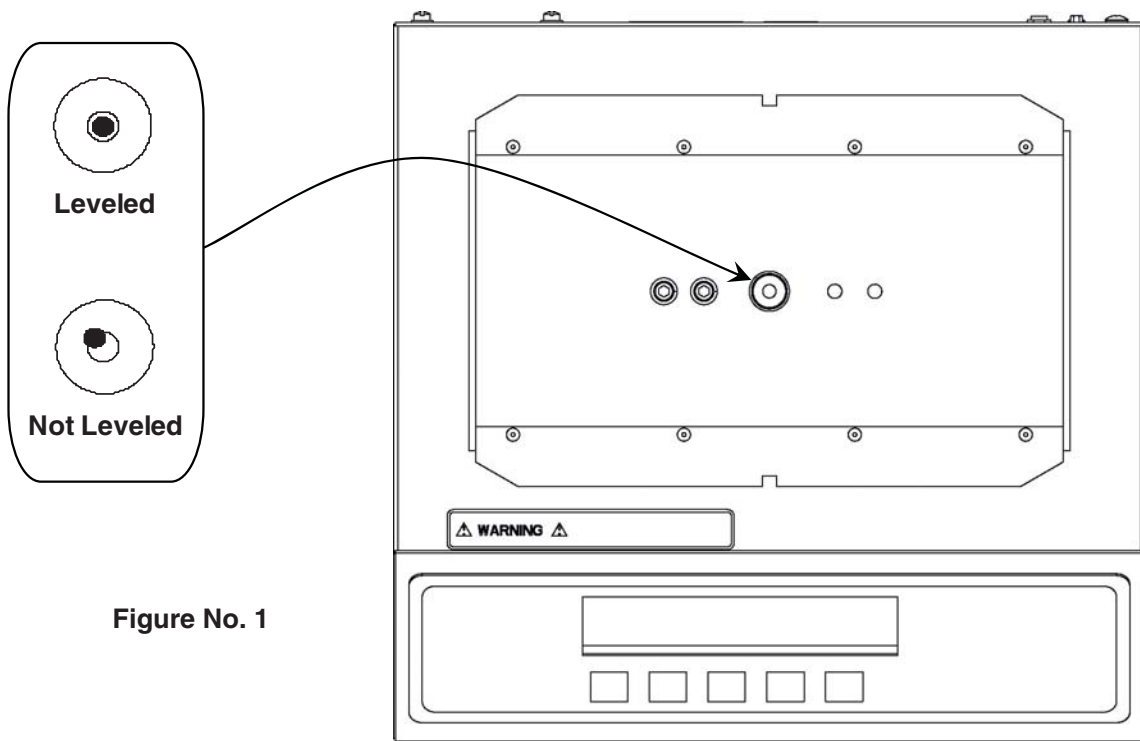

Figure No. 1

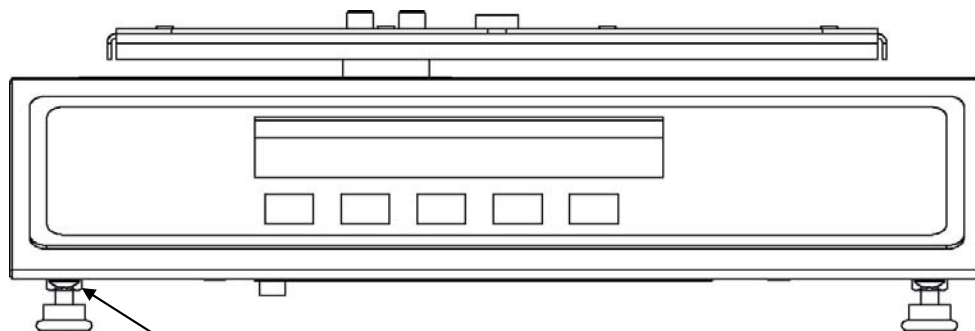

Figure No. 2

Locking Nut
Mounting Foot

INSTALLATION, Cont.

Baby Tray Installation

Before using the scale, it will be necessary to install the baby tray and batteries. Note that the baby tray is designed to lock into place on the scale weighbridge preventing accidental separation from the scale.

Follow the steps listed below to install the baby tray. Refer to figure No. 3.

- Step 1 Place the scale on a table top.
- Step 2 Position the baby tray onto the weighbridge.
- Step 3 Slide the baby tray onto the weighbridge until you hear the release knob “click”.
- Step 4 Verify the baby tray is locked in place by making certain that it cannot be slide to the left or right.



CAUTION! Make absolutely certain that the baby tray is locked in place before using the scale. Be sure that the locking knob is in the locked position. Failure to lock the baby tray in place can result in injury to the baby should the tray separate from the scale.

Figure No. 3

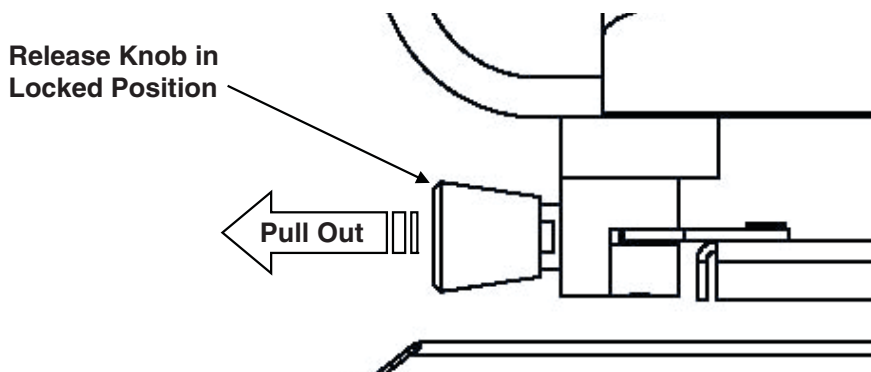
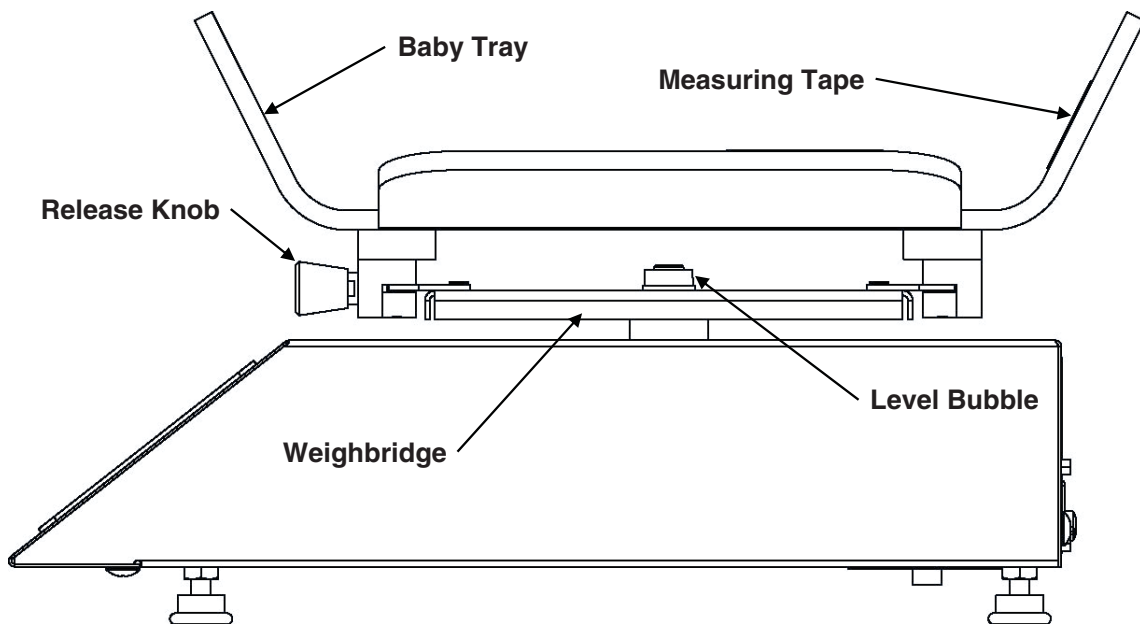

To remove baby tray from scale, pull Release Knob and slide tray off weighbridge.

INSTALLATION, Cont.

Battery Installation

The 6745 Baby Scale can use 6 "C" size Alkaline, Ni-Cad or NiMH batteries (*not included*). If you wish to operate the scale from batteries, you must first obtain and install batteries before operations can begin. The batteries are contained in a battery holder inside the scale. Access is via a removable panel on the bottom of the scale.

The scale can operate for 200 hours of continuous use when using Alkaline batteries or with fully charged Ni-Cad or NiMH batteries, 50 hours of continuous use.

NOTE! When using Alkaline batteries, make sure the *niCad* setup option is disabled (set to 0). Refer to Setup and Calibration or Setup Review.

Use the following procedure to install the batteries.

- Step 1 With the baby tray installed, turn the scale upside down on a stable surface.
- Step 2 Locate the rectangular panel on the bottom of the scale and remove the thumb screw retaining it.
- Step 3 Remove the panel (lift straight up and slide it out) exposing the battery holder.
- Step 4 Install 6 "C" size batteries in the holder, making certain they are positioned in accordance with the polarity markings located in the battery holder. Refer to Figure No. 4.
- Step 5 After placing all 6 batteries in the battery holder, replace the panel on the bottom of the scale (slide the tab in the slot on the scale) and install the thumb screw.

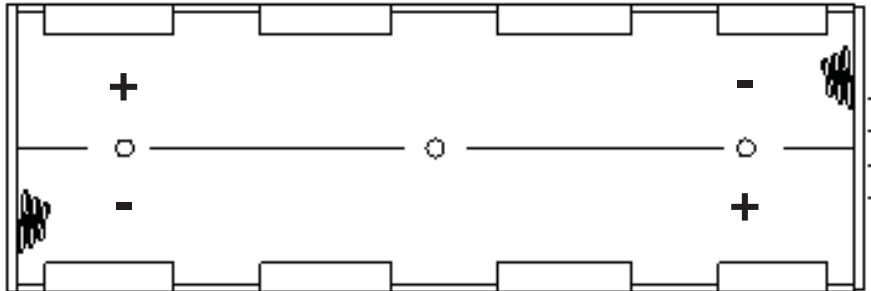

Figure No. 4

- Step 6 Turn the scale over and press the **ON** key.
- Step 7 If the display turns on, the batteries have been installed correctly. If not, turn the scale over, remove the panel and check for one or more improperly positioned batteries.



The 6745 Baby Scale can be operated from a power supply or from Alkaline, Ni-Cad or NiMH batteries. All six (6) batteries must be of the same type. They must all be Alkaline, all Ni-Cad or all NiMH. DO NOT mix Alkaline and Ni-Cad or NiMH batteries. The power supply is also used to recharge the batteries, when the scale is operated from Ni-Cad or NiMH batteries. DO NOT connect a power supply to the scale if using Alkaline batteries.

INSTALLATION, Cont.

Low Battery Indicator

When the batteries are near the point they need to be replaced (Alkalines) or recharged (NiCad or NiMH), the low battery annunciator on the display will turn on (see Figure No. 5) If the battery voltage drops too low for accurate weighing, the scale will automatically shut off and you will be unable to turn it back on.

If using Alkaline batteries when the low battery annunciator turns on, turn the scale off, remove the old batteries and replace with new ones. Follow the same procedure for installing batteries when battery replacement becomes necessary.

If using NiCad or NiMH (and the *niCad* setup option is enabled, set to 1 or 2), plug the power supply into the scale and then into the proper electrical wall outlet. The scale will begin charging the batteries.

Battery Status

If batteries are used, the scale will show the battery status on power up. The display will show *bAttery* then change to $\equiv YY \equiv$, where YY indicates the remaining battery voltage expressed as a percentage (%) of the total battery voltage.

Battery Charging

To recharge the Ni-Cad or NiMH batteries, the power supply must be connected to a AC power outlet and plugged into the scale. It will take approximately 15 hours to fully recharge the batteries in the scale. While the batteries are charging the scale can still be operated. Note that charging the batteries for more than 15 hours *will not* damage them.

When the scale is to be turned off, pressing the **OFF** key once will display "dashes" scrolling across the display indicating the batteries are being charged. Pressing the **OFF** key again, will display *OFF* and turn the scale off. If the power supply is disconnected before the 15 hours, the scale will continue to charge the batteries when the power supply is plugged back in. Note that the auto-shutdown feature (if enabled during setup and calibration) will be disabled when the scale is charging the batteries.

NOTE! When the scale is turned off, it is NOT charging the batteries.

Placing the Scale

After the batteries have been installed, the scale may be prepared for use. Place the scale on a stable, vibration-free level surface away from direct sunlight and from any rapidly moving air source (heating/cooling vents, fans, etc.). Make certain the power cord and peripheral cables are routed out of the way of normal traffic. If the scale is unstable, adjust the front legs up or down as necessary until the scale is stable.



CAUTION! Make certain that the structure beneath the scale is of sufficient strength to hold both the scale AND the maximum load to be placed on the scale. Failure of the supporting structure can result in an injury to the baby in the baby tray, as well as damage to the scale.

Installation of the scale is now complete. Please read the operating instructions contained in this manual before attempting to operate your scale.

KEYPAD FUNCTIONS

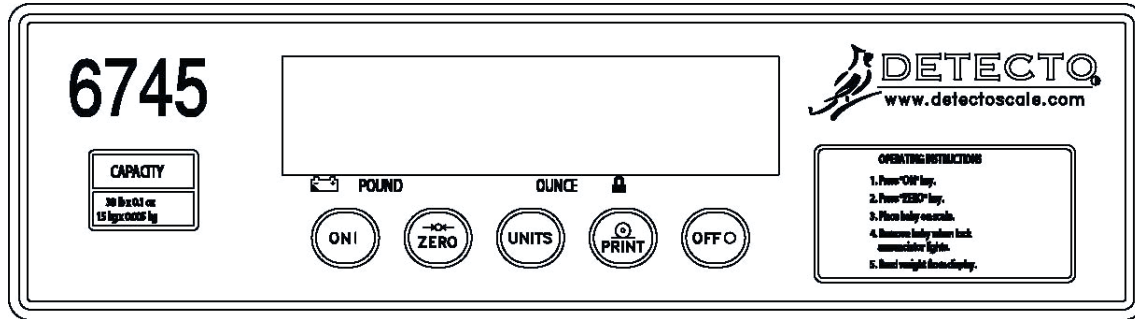

Figure No. 5



The membrane keypad is not to be operated with pointed objects (pencils, pens, fingernails, etc). Damage to keypad resulting from this practice is NOT covered under warranty.

ON I

With the indicator off, pressing this key will apply power to the scale and turn on the display.

OFF O

If the scale is on, pressing this key will remove power from the scale.

→○← ZERO

This key is used to reset the display to zero up to the limit set during setup and calibration of the scale. (See Setup and Calibration, USA)

UNITS

This key is used to change the weighing units to the alternate units of measurement if selected during setup of the scale (WEIGHTING UNITS = 2 or 3). For example, with pounds displayed (lb annunciator turned on) pressing this key will change the weighting units to kilograms (kg annunciator will turn on). **NOTE!** This feature must be enabled during setup and calibration for this key to be operational. This key is also used during setup and calibration to toggle between the values.

⊙ PRINT

If an optional printer is connected to the scale, and the weight display is locked on the baby's weight, pressing this key will send the weight data to the printer. **NOTE!** This key is also used during setup and calibration to display and then save the current setting.

NOTE! The scale will not respond to pressing the PRINT key unless the weight display is stable and the Weight Lock annunciator is turned on.

ANNUNCIATORS

The annunciators are turned on to indicate that the display is in the mode corresponding to the annunciator label or that the status indicated by the label is active.

(Center-of-Zero)

The Center-of-Zero annunciator is located to the lower right of the ounce weight display and is turned on to indicate that the weight is within +/- 1/4 division of the center of zero.

(Stable)

The (Stable) annunciator is located to the far lower right of the ounce weight display and is turned on when the weight display is stable. When off, it means that the change in successive weight samples is greater than the motion limits selected during setup and calibration.



POUND

The POUND annunciator is located on the left of the weight display and is turned on when the pounds & ounces mode is selected to show that the displayed weight is pounds.



OUNCE

The OUNCE annunciator is located slightly to the right center of the weight display and is turned on when the pounds & ounces mode is selected to show that the displayed weight is ounces.

kg

The kg annunciator is located on the right of the weight display and is used to indicate that the displayed units of weight measurement is kilograms.



LOW BATTERY

The low battery annunciator is used with the battery operation. It will turn ON to indicate that the batteries will soon need to be replaced (if using Alkaline) or recharged (if using NiCad or NiMH). No change in operation will occur until just before the battery voltage drops to a level where operation is affected. At this level, the indicator will automatically turn itself off.



WEIGHT LOCK

The WEIGHT LOCK annunciator is turned on to show that the scale is locked onto the weight.

OPERATION

The following steps describe the operation of the Model 6745 Baby Scale. Note that a set of condensed instructions appear on the face of the scale as well.

Basic Weighing Operation

- Step 1 Press the **ON** key. The scale display will turn on showing the model number, battery status and if the threshold feature is enabled, the last locked weight will display. Press the **UNITS** key to select the desired weighing unit. Note that pressing the **UNITS** key causes the scale to alternate between pounds & ounces and kilograms. Annunciators will turn on to indicate which weighing units have been selected.
- Step 2 If desired, a blanket or similar covering may be placed in the baby tray at this time. Make certain that the blanket does not extend over the tray and touch surrounding objects (including the scale enclosure) or the weight reading could be incorrect. Press the **ZERO** key and make certain that the display shows a zero weight reading.
- Step 3 Place the baby in the baby tray and observe the scale display. If the threshold feature was enabled during setup and calibration, in a few seconds the Weight Lock annunciator will turn on, signaling that the weight display is locked and the baby may be removed from the scale. Note, that if a printer is attached to the scale, the weight data will automatically print.
- Step 4 Remove the baby from the scale.
- Step 5 Record the baby's weight from the weight display. Note that after a short period of non-use the scale will turn off. To resume operation, press the **ON** key.

OPERATING HINTS

- A. Remember that all items (blankets, pads, toys, etc.) that are not to be included in the weight should be placed on the baby tray and the **ZERO** key pressed. This will insure that the item(s) will not be included in the child's weight.
- B. If the child is very active it may take a few seconds longer for the Weight Lock annunciator to turn on. During this time the scale's is busy calculating the weight.
- C. If the scale is not in use, press the **OFF** key to conserve battery life. Note that if the Sleep Mode was activated during setup and calibration, the scale will turn off automatically after the time set for the sleep mode.

CARE AND CLEANING

1. **DO NOT** submerge the scale in water, pour or spray water directly on it.
2. **DO NOT** use acetone, thinner or other volatile solvents for cleaning.
3. **DO NOT** expose the scale to temperature extremes.
4. **DO NOT** place the scale in front of heating/cooling vents.
5. **DO** clean the scale with a damp soft cloth and mild non-abrasive detergent.
6. **DO** remove power before cleaning with a damp cloth.
7. **DO** provide clean AC power and adequate protection against lightning damage.
8. **DO** keep the surroundings clear to provide clean and adequate air circulation.

PRINTER OUTPUT

The Model 6745 Baby Scale has a RS-232 serial port that may be connected to an optional printer to record weight. The output connector is located on the rear panel (see Figure No. 6).

When the weight display is locked on the baby's weight and the Weight Lock annunciator is turned on, the weight data may be transmitted by pressing the **PRINT** key or on demand with receipt of a command from a computer). **NOTE!** If the threshold feature was enabled during setup and calibration, with a printer attached to the scale, the weight data will automatically print when the weight display locks on the baby's weight.

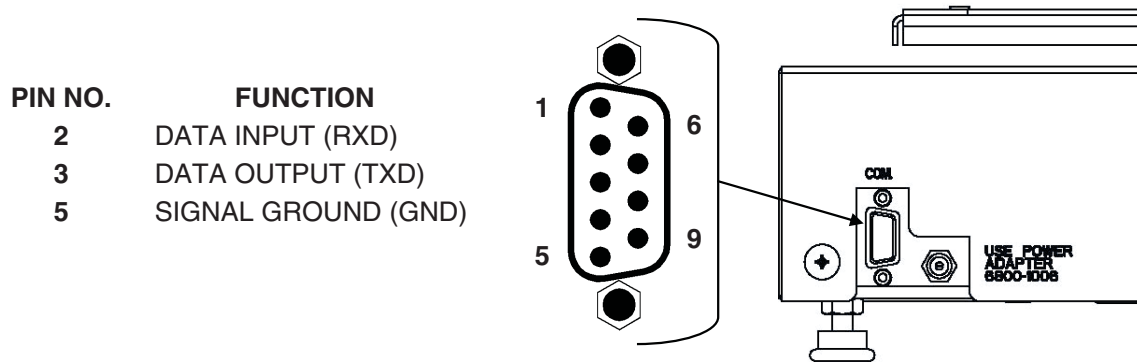

Figure No. 6

The serial port can be configured during the setup and calibration procedure or during the setup review operation. Using either method, it is possible to select the baud rate, data format and print ticket format. **NOTE!** The scale is shipped with the baud rate set to 9600 baud.

SERIAL DATA FORMATS

If the scale is connected to a computer, it will transmit a single set of weight data each time the computer sends an ENQ (hex 05) or a SMA weight request (W). Examples and explanation of the data format transmitted are shown below.

The host device (computer) sends:

ENQ (hex 05) or <lf> W <cr>.

The scale will respond with:

<lf><s><r><n><m><xxxxxxxxxx><uuu><cr>.

Where:

lf =	Line Feed	
s =	Flags	Z= center of Zero O = Over cap E = zeroError, e = weight not currently being displayed
r =	Range	1, 2, 3, ...
n =	Mode	G = Gross
m =	Motion	M = Motion, " "(blank) = no motion
xxxxx:xx.x =	Weight	Ten digits (includes decimal point), lb/oz mode
xxxxxx.xxx =		Ten digits (includes decimal point), kg mode Weight is right justified.
uuu =	Units	l/O^ (lb & oz), kg^ (kilograms), (^ = space)
cr =	Carriage Return	(hex 0D)

SETUP AND CALIBRATION

Your scale was calibrated at the factory and should not require adjustment. In the event that it should need recalibration, the following describes the calibration procedure. A qualified technician should perform this procedure to maintain the scale's high degree of accuracy.

Before beginning calibration, the following equipment is required:

- 30 lb Calibrated test weight
- 3/16 slotted screwdriver (to remove calibration sealing screw)
- A small non-metallic tool (to depress calibration switch)

To enter the setup and calibration mode:

1. With the power off, remove the Calibration Access Screw on the lower left corner of the rear panel, see Figure No.7.
2. With the screw removed, insert a small non-metallic tool into the screw hole and press and hold the calibration switch.
3. Press the **ON** key.
4. The display will show *int.* The indicator is now ready for setup and calibration.

Figure No. 7

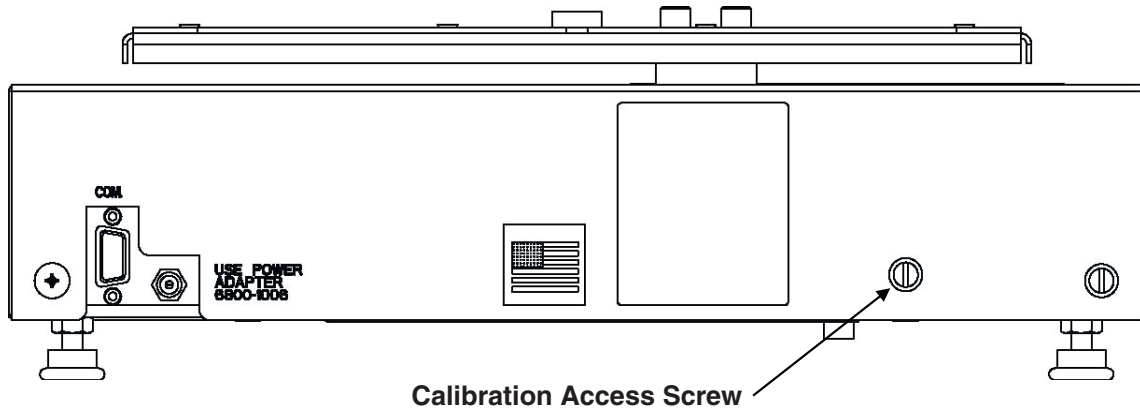

During the setup and calibration process it will be necessary to enter data using the scale's keyboard. Pressing the **PRINT** key will show the current value of a setting. Pressing the **PRINT** key again will save the displayed setting value and advance to the next prompt. To change a setting, press the **UNITS** key to "toggle" between the different available values. On settings with 2 digit values, press the **ZERO** key to advanced to the next position. Note that the blinking character is the cursor location of the value to be changed.

Scale Interval

With the display showing *int.*, press the **PRINT** key to show the current setting. If the value displayed is acceptable, press the **PRINT** key again to save it. Otherwise use the **UNITS** key to select the new setting and then press the **PRINT** key to save it. Allowable values for the scale interval are: 1, 2 or 5.

SETUP AND CALIBRATION, Cont.

Weighing Units

With the display showing *Unit=* press the **PRINT** key to show the current setting. If the value displayed is acceptable, press the **PRINT** key again to save it. Otherwise use the **UNITS** key to select the new setting and then press the **PRINT** key to save it. Allowable values are:

- | | |
|--|--|
| 0 = Pounds & Ounces Only | 1 = Kilograms Only |
| 2 = Pounds & Ounces / Kilograms | 3 = Kilograms / Pounds & Ounces |

Scale Capacity

With the display showing *CAP=* press the **PRINT** key to show the current setting. Press the **UNITS** key to enter the proper digit at the blinking location. Press the **ZERO** key to step to the left and the next digit location. Repeat the process until all digits of the capacity have been entered. After all digits have been correctly entered, press the **PRINT** key to store the capacity and advance to the next step. Allowable values are 0 through 99.

Calibration

With the display showing *CAL=* press the **PRINT** key. The display will change to show the current setting *0* (0=NO). If the scale has been previously calibrated and you wish to skip calibration and proceed to *AGCC=*, the Acceleration of Gravity, simply press the **PRINT** key and the internal calibration factor will be retained.

To begin calibration, press **UNITS** to select *1* (1=YES), then press the **PRINT** key. After pressing the **PRINT** key the display will change to *LOAD=*.

Load Calibration Weight

The scale will now display *LOAD=* which is a prompt for the entry of the calibration weight value and placement of this amount of test weights on the scale platform.

1. Make certain the scale platform is empty (remove any blankets or similar covering), then place the calibrated test weights on the scale platform. **NOTE!** It is recommended that a minimum of 50% of the scale's capacity be used but 70% to 100% is preferred.
2. Press the **PRINT** key.
3. Determine the exact amount of test weights to be placed on the scale platform and enter this value into the scale by using the **UNITS** and **ZERO** keys in the same manner used to enter the scale's capacity.
4. Verify that the numbers entered are the same as the total weight of test weights, and the least significant digit agrees with the scale interval.
5. Press the **PRINT** key.

After a moment the scale will display the message *unLOAD* which is a request that the test weights be removed from the scale platform. Remove the weights then press the **PRINT** key. The calculated calibration factor is now stored in the scale's nonvolatile memory.

SETUP AND CALIBRATION, Cont.

Acceleration of Gravity

This scale is equipped with an acceleration of gravity function which means that it can be calibrated in one location and then adjusted to match the acceleration of gravity at the location where it will be used.

With the display showing *AGCC=* press the **PRINT** key to show the current setting. If the value displayed is acceptable, press the **PRINT** key to save it. Otherwise use the **UNITS** key to select the new setting and then press the **PRINT** key to save it.

- 0 Use Default Acceleration of Gravity
- 1 Enter Acceleration of Gravity Values

NOTE! If you select 1 (Enter Acceleration of Gravity Values) the following additional prompts will be displayed:

Acceleration of Gravity (Calibration Location)

The display will change to show *CALGC=*. Press the **PRINT** key to show the current setting. This is the acceleration of gravity value of the location where the scale was calibrated. If the value displayed is acceptable, press the **PRINT** key to save it. Otherwise press the **UNITS** key to enter the proper digit at the blinking location. Press the **ZERO** key to step to the left and the next digit location. Repeat the process until all digits have been entered. After all digits have been correctly entered, press the **PRINT** key to store the value and advance to the next step. Consult the factory for the Acceleration of Gravity value for your location.

Acceleration of Gravity (Operation Location)

The display will change to show *OPGC=*. Press the **PRINT** key to show the current setting. This is the acceleration of gravity value for the location where the scale will be operated. If the value displayed is acceptable, press the **PRINT** key to save it. Otherwise press the **UNITS** key to enter the proper digit at the blinking location. Press the **ZERO** key to step to the left and the next digit location. Repeat the process until all digits have been entered. After all digits have been correctly entered, press the **PRINT** key to store the value and advance to the next step. Consult the factory for the Acceleration of Gravity value for your location.

Zero Tracking Range

With the display showing *ZTR=* press the **PRINT** key to show the value assigned to the automatic Zero Tracking Range. This is the value in scale divisions that will be automatically zeroed off. Use the **UNITS** key to step through the values. Once the proper value is shown press the **PRINT** key to store the value. Allowable values are:

- 0 Disable Zero Tracking
- 1 .5d (0.5 division) Zero Tracking
- 2 1d (1 division) Zero Tracking

SETUP AND CALIBRATION, Cont.

USA (Domestic or International)

The display will change to show *USA=*. This is the prompt to select whether the scale is used in the USA (Domestic) or outside the US (International). Press the **PRINT** key to show current setting. If the value displayed is acceptable, press the **PRINT** key again to save it. Otherwise use the **UNITS** key to select the new setting and then press the **PRINT** key to save it.

USA = 1 (Domestic)

No Zero Limit
Threshold Lock Feature Enabled

USA = 0 (International)

+/- 2% Zero Limit
Threshold Lock Feature Disabled
Lamp test on power up enabled (display segments 1 second on, 1 second off)

Digital Filter Level Selection

Your scale will arrive with the factory filter setting (1=minimal) already entered. Please check with your scale service technician should you wish to change the programmed filter level and break range.

With the display showing *FLT=*, press the **PRINT** key to show the current setting. If the value displayed is acceptable, press the **PRINT** key again to save it. Otherwise use the **UNITS** key to select the new setting and then press the **PRINT** key to save it. Four levels of filtering are available. They are as follows:

0 = NO FILTERING

1 = MINIMAL FILTERING

2 = MODERATE FILTERING

3 = CUSTOM FILTERING



NOTE: Selection 3, Custom Filtering is used when 0, 1 or 2 are inadequate.

F= - Filter Level

If you select Custom Filtering, the scale will display *F=*. Press the **PRINT** key to show the current setting for the Filter Level. The filter level is a number from 1 to 16 that corresponds to the level of filtering with 16 being the greatest filtering and 1 the least. Use the **UNITS** and **ZERO** keys to select the filter level, and then press the **PRINT** key to save the setting. Allowable values are: 1 through 16.

br= - Break Range

Next, the scale will display *br=*. Press the **PRINT** key to show the current setting for the Break Range. The break range is a number from 1 to 64 that corresponds to the number of division change to break out of filtering. Use the **UNITS** and **ZERO** keys to select the break range value, and then press the **PRINT** key to save the setting. Allowable values are: 1 through 64.

Sample Rate

The display will change to show *Sr=*. Press the **PRINT** key to show the current setting. The sample rate may be set from a minimum of 1 sample per second to a maximum of 10 samples per second in one sample per second intervals. Use the **UNITS** and **ZERO** keys to select the desired sample rate and then press the **PRINT** key to save the setting. Allowable values are: 1 through 10.

SETUP AND CALIBRATION, Cont.

Battery Type

With the display showing *niCd*= press the **PRINT** key to show current setting. If the value displayed is acceptable, press the **PRINT** key again to save it. Otherwise use the **UNITS** key to select the new setting and then press the **PRINT** key to save it. **NOTE!** This setting may be revised without having to enter the calibration mode. Allowable values are:

- 0 Alkaline batteries - battery charging is DISABLED
- 1 NiCad or NiMH batteries - battery charging is ENABLED
- 2 Battery charging is ENABLED and FORCED ON. This selection forces battery charging for NiCad or NiMH batteries that are discharged. **NOTE!** After 15 hours of charging, the indicator will automatically change the *niCd*= setting back to a 1.



CAUTION! Selecting 1 or 2, enables battery charging. **DO NOT** select 1 or 2, when using Alkaline batteries.

Threshold

NOTE! This prompt will only be displayed if you selected *USA* = 1 (Domestic).

The display will change to show *LHrSh*=, the threshold lock value. This value is the weight in ounces that the load on the scale must rise above for the Weight Lock feature to function.

Press the **PRINT** key to show the current setting. If the value displayed is acceptable, press the **PRINT** key again to save it. Otherwise, use the **UNITS** and **ZERO** keys to enter a new value and then press the **PRINT** key to save it. Allowable values are: 0 through 99. Note, that a setting of 0 will disable the threshold lock.

Power Up Zero

With the display showing *PUD*= press the **PRINT** key to show current setting. If the value displayed is acceptable, press the **PRINT** key again to save it. Otherwise use the **UNITS** key to select the new setting and then press the **PRINT** key to save it. **NOTE!** This setting may be revised without having to enter the calibration mode.

- 0 Power Up Zero is DISABLED
- 1 Power Up Zero is ENABLED. The weight display will be reset to zero automatically when the scale is turned on.

Automatic Shutoff

The Automatic Shutoff feature will automatically turn the scale off after a predetermined period of inactivity to prolong battery life. To turn the scale back on you must press the **ON** key.

With the display showing *ASH*=, press the **PRINT** key to show the current setting. If the value displayed is acceptable, press the **PRINT** key again to save it. Otherwise, use the **UNITS** key to select the number of minutes (*time approximate*) of inactivity before turning the scale off and then press the **PRINT** key to save it. **NOTE!** This setting may be revised without having to enter the calibration mode. Allowable values are 0 through 9. Note that 0 disables the Automatic Shutoff feature.

SETUP AND CALIBRATION, Cont.

Sleep Mode

The Sleep Mode feature also conserves battery power when the scale remains unused for a selected period of time. With the feature enabled, the load cell excitation will be reduced and the display will show *SLEEP*. The Sleep feature requires that the scale remain at the center of zero to activate, unlike the Automatic Shutoff feature which only requires no motion. Weight placed on the scale will activate the scale and return it to the weight mode.

With the display showing *SLP=*, press the **PRINT** key to show the current setting. If the value displayed is acceptable, press the **PRINT** key again to save it. Otherwise, use the **UNITS** key to select the number of minutes (*time approximate*) of inactivity at zero before the scale will enter the Sleep mode. Press the **PRINT** key to save the setting. **NOTE!** This setting may be revised without having to enter the calibration mode. Allowable values are 0 through 9. Note that 0 disables the Sleep mode.

Baud Rate Selection

With the display showing *bAUD*, press the **PRINT** key to show the current setting. If acceptable, press the **PRINT** key to save it. Otherwise use the **UNITS** key to select the new setting and then press the **PRINT** key to save it. **NOTE!** The FACTORY setting is 3 (9600 baud) and may be revised without having to enter the calibration mode. The following baud rates are available:

0 = 1200	1 = 2400	2 = 4800
3 = 9600	4 = 19,200	5 = 38,400

Serial Data Format

With the display showing *PrLy=*, press the **PRINT** key to show the current setting. If acceptable, press the **PRINT** key to save it. Otherwise use the **UNITS** key to select the new setting and then press the **PRINT** key to save it. Allowable values 0, 1 or 2.

0	8 data, no parity, 1 stop bit (8, N, 1)
1	7 data, odd parity, 1 stop bit (7, O, 1)
2	7 data, even parity, 1 stop bit (7, E, 1)

Print Ticket Format

This setting determines whether weight data transmitted by the serial port is formatted for the P220 printer or the P185 printer and enables Journal mode or Ticket mode.

With the display showing *PrL=*, press the **PRINT** key to show the current setting. If acceptable, press the **PRINT** key to save it. Otherwise use the **UNITS** key to select the new setting and then press the **PRINT** key to save it. Allowable values 0, 1 or 2.

NOTE! If you select 1 (Set Serial Format for P185 Printer Ticket Mode) an additional prompt (*EDP=*) will be displayed.

0	P220 Serial Format is Enabled
1	Enable Serial Format for P185 Printer in Ticket Mode
2	Enable Serial Format for P185 Printer in Journal Mode

SETUP AND CALIBRATION, Cont.

End-Of-Print Line Feeds

At the end of a data transmission to a printer, the scale can send a number of line feed commands to space the paper in the printer to the desired position for withdrawal or for the next print. **NOTE!** This prompt will only be displayed if you select $PrL= 1$.

With the display showing $EoP=$, press the **PRINT** key to show the current setting. If acceptable, press the **PRINT** key to save it. Otherwise use the **UNITS** key to select the new setting and then press the **PRINT** key to save it. **NOTE!** This setting may be revised without having to enter the calibration mode. Allowable values are: 00 through 99.

Setup And Calibration Is Completed

The setup and calibration process has been completed. The scale will reset and then display weight. Replace the calibration screw removed earlier. The scale is ready to begin normal operation.

SETUP REVIEW

The 6745 Baby Scale allows several operational parameters to be reviewed and changed as necessary without having to enter the setup and calibration mode. The parameters in the setup review will be processed in the following sequence:

$NiCad=$	0 = Disable battery charging (use Alkaline batteries) 1 = Enable battery charging (use Ni-Cad or NiMH) 2 = Enable battery charging and Force charging of discharged Ni-Cad or NiMH batteries.
$LHrSh=$	Enable or Disable the threshold lock and select the weight that the load on the scale must rise above to begin displaying weight
$PUO=$	Enable or Disable automatic reset of weight display to zero when scale is turned on
$ASH=$	Disable or select number of minutes for automatic shutoff timer
$SLP=$	Disable or select number of minutes of inactivity at zero for sleep mode
$BAUD=$	Select baud rate for serial printer port.
$PrLY=$	Select the serial data format.
$PrL=$	Select the ticket format to be used when the PRINT key is pressed.
$EoP=$	The Number of Ending Linefeeds Printed.

To enter the setup review mode:

1. Press the **OFF** key to turn the scale off
2. Press and hold the **PRINT** key and then press the **ON** key.
3. The display will then prompt with $niCad$, the selection to use Ni-Cad (NiMH) or Alkaline batteries.
4. Refer to the instructions listed in the Setup and Calibration section of this manual for information on how to change these parameters.

ERROR AND STATUS DISPLAYS

The Model 6745 Baby Scale is equipped with a diagnostic software program that tests various portions of the scale's circuitry and verifies proper operation. Should a problem be detected, an error or status message will be displayed alerting the operator to that condition. The following lists these errors and status displays and their meaning:

Display	Meaning
<i>-UnS-</i>	Motion is present when the scale is attempting to perform one of the following operations: Power Up Zero or Zero Weight Display
<i>-OF-</i>	Attempting to display a negative number greater than -99,999 or a positive number greater than 99,999
<i>-OCAP-</i>	Scale weight exceeds scale capacity
<i>CALib</i>	Indicates improper stored calibration data, calibration is necessary.
<i>Ad Err</i>	The analog to digital circuit has failed. Consult your scale service representative.
<i>Err A</i>	The analog to digital sample is invalid.
<i>ErrAL</i>	The load cell input is below the range of the scale.
<i>ErrAH</i>	The load cell input is above the range of the scale.
<i>EE Err</i>	NOVRAM failure. Consult the scale service representative.
<i>-tL-</i>	Indicates an attempt to zero a weight outside the scale zero range.
<i>battery</i>	Indicates the remaining battery voltage expressed as a percentage (%) of the total battery voltage.
<i>-Err-</i>	General error, invalid keypad entry was attempted.
<i>E-Unit</i>	Displayed when the UNITS key is pressed and only a single weighing units mode (0, pound & ounces or 1, kilograms) was selected during setup and calibration.
<i>OFF</i>	Displayed to indicate the scale is turning off.

BEFORE YOU CALL FOR SERVICE

Your scale has been designed to provide you with years of trouble-free operation. In spite of this, troubles sometimes happen. Before calling for service assistance you should make some initial checks to verify that a problem does exist. The following describes several types of symptoms along with suggested remedies.

Problem	Possible Solutions
Display does not turn on	<p><u>AC Operation:</u> Is the AC power cord fully inserted into the wall receptacle? Check wall receptacle for proper AC power. Try another electrical appliance in the same receptacle, does it work? Check the circuit breaker. Has there been power failure?</p> <p><u>Battery operation:</u> Check if batteries are installed and correctly. Are batteries discharged? Replace if Alkaline or recharge if NI-CAD or NiMH.</p>
Incorrect weight displayed	Insure that the baby tray isn't touching an adjacent object. Have proper operation procedures been followed?
Indicator will not display weight	Refer to Error and Status Display section and make certain that the <i>OCAP</i> message is not displayed. If so, and scale is not loaded, consult your scale service representative.

PART IDENTIFICATION

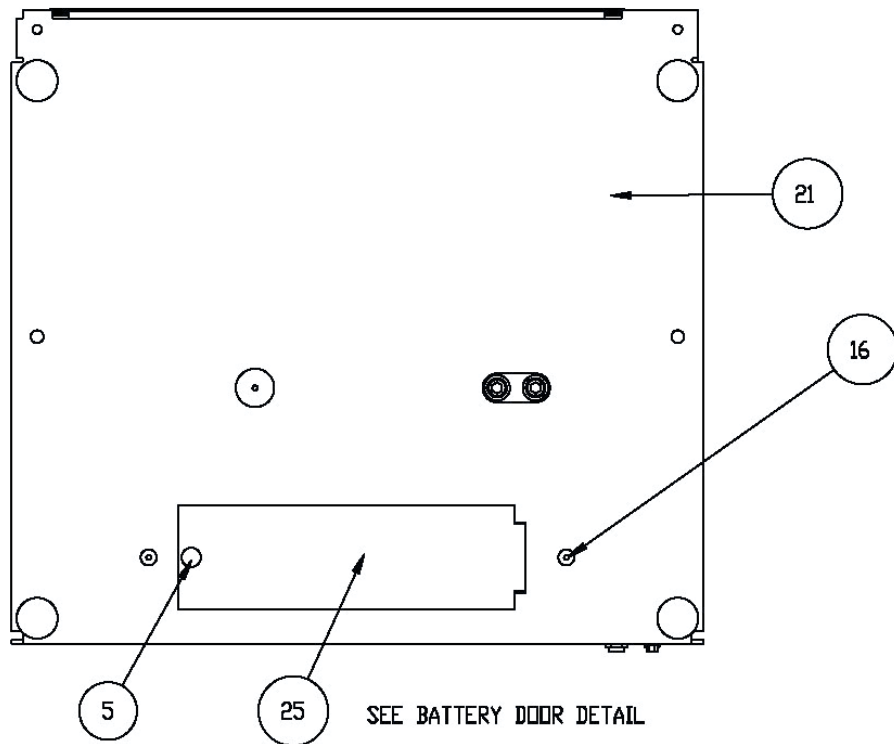
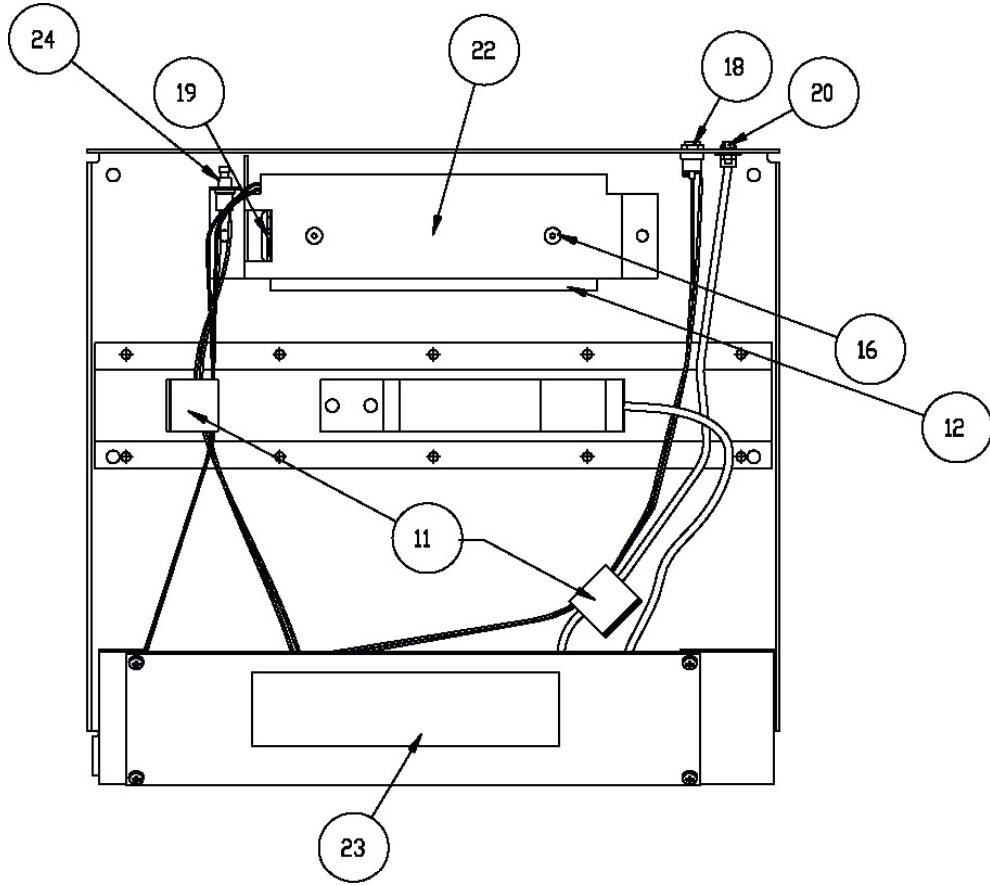

PART IDENTIFICATION, Cont.

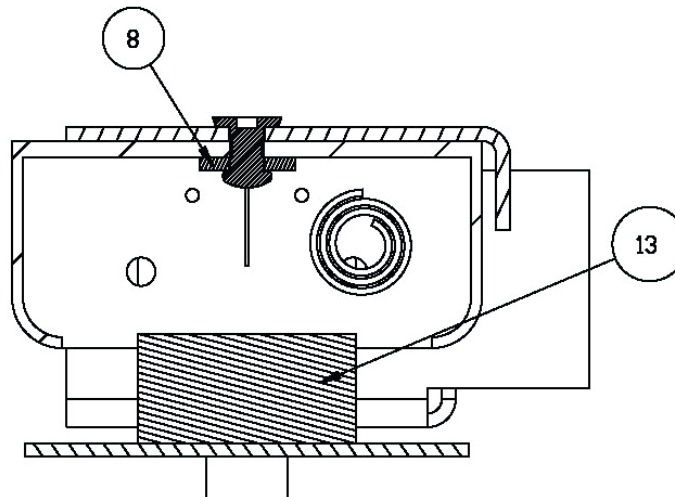
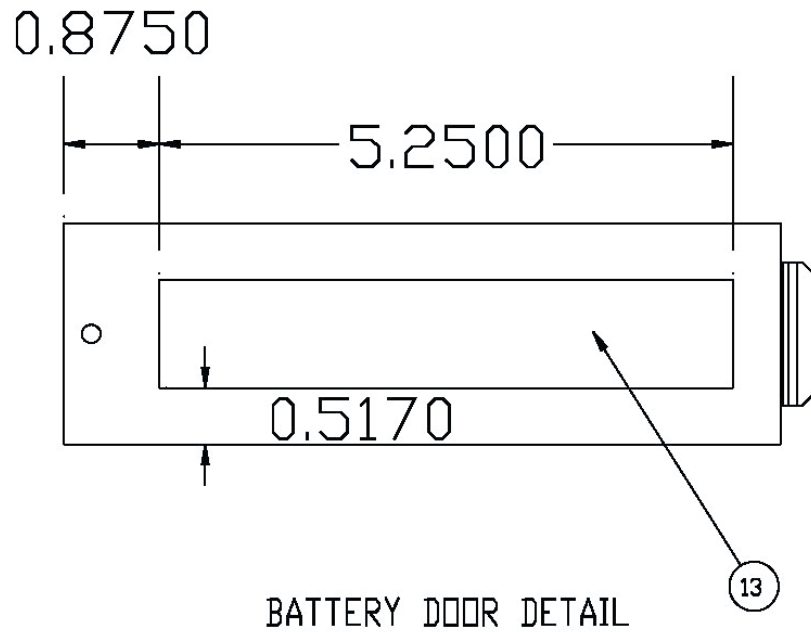
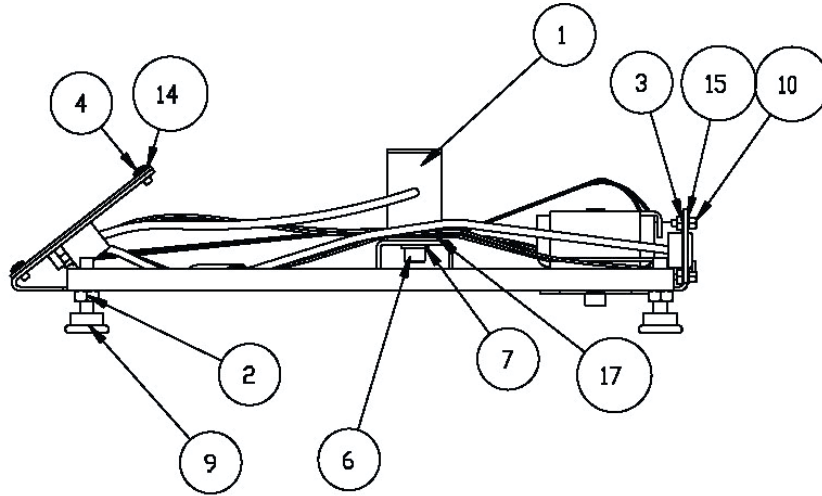

PART IDENTIFICATION, Cont.

ITEM NO.	QTY	PART NUMBER	DESCRIPTION
1	1	2950-C118-1A	20KG LOAD CELL CABLE ASSEMBLY
2	4	6013-0045	NUT HEX 1/4-20
3	2	6013-0245	NUT HEX #4-40
4	4	6021-0654	SCW PAN HEAD #6-32 X .250 PDMS
5	1	6021-1032	THUMB SCRW, 6-32 X 0.25
6	2	6021-1429	1/4-20 X 0.75 SHCS
7	2	6024-0039	WASHER LOCK HELICAL 1/4 REG.
8	2	6024-0126	WASHER #6 FLAT Z/P
9	4	6540-1011	LEVELER SCREW 1/4-20 X 1 S.S.
10	2	6610-2000	JACK SOCKET
11	2	6610-5007	CABLE CLIP
12	1	6610-5119	BATTERY HOLDER 6-C CELLS
13	1	6650-0018	GASKET MATERIAL 1" X 1/2" X 5 1/4"
14	4	6680-0004	WASHER LOCK INT. TOOTH #6 Z/P
15	2	6680-0052	WASHER LOCK #4 Z/P
16	4	6680-0214	RIVET POP, BH AL 5/32 DIA X 0.126 -.187 GR
17	1	8526-B214-08	LOAD CELL SPACER
18	1	8535-B050-0A	POWER CABLE
19	1	8535-B051-0A	CABLE: BATTERY
20	1	8535-B063-0A	SERIAL CABLE
21	1	8535-C054-0A	BASE WELDMENT
22	1	8535-C059-08	BATTERY MOUNT
23	1	8535-D043-0A	PCB ASSEMBLY – 6745 MAIN
24	1	8539-B254-0A	ASSEMBLY: CABLE, CALIBRATION SWITCH
25	1	8555-B166-08	BATTERY DOOR

PART IDENTIFICATION, Cont.

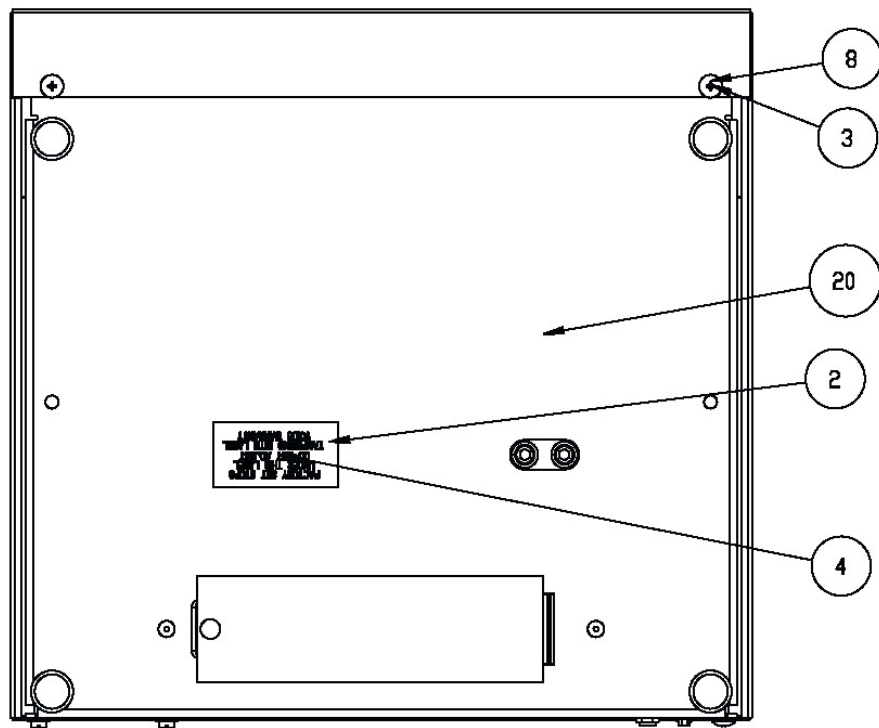
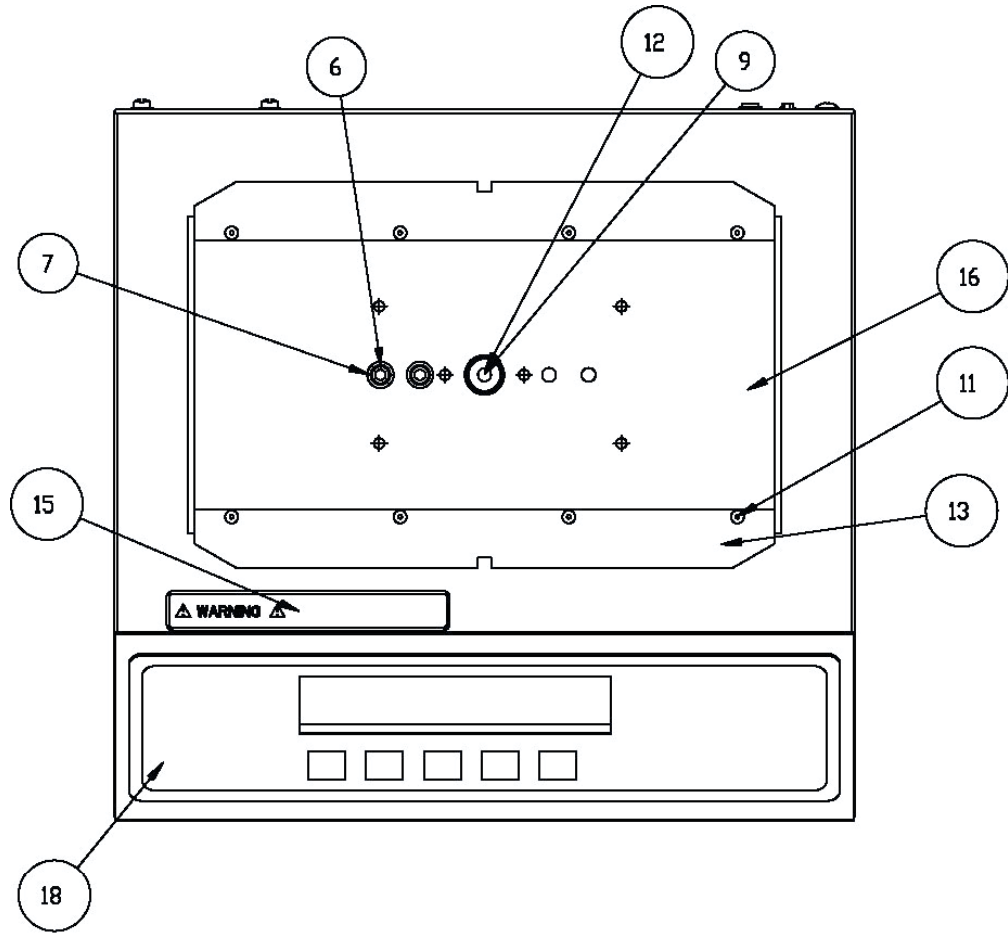

PART IDENTIFICATION, Cont.

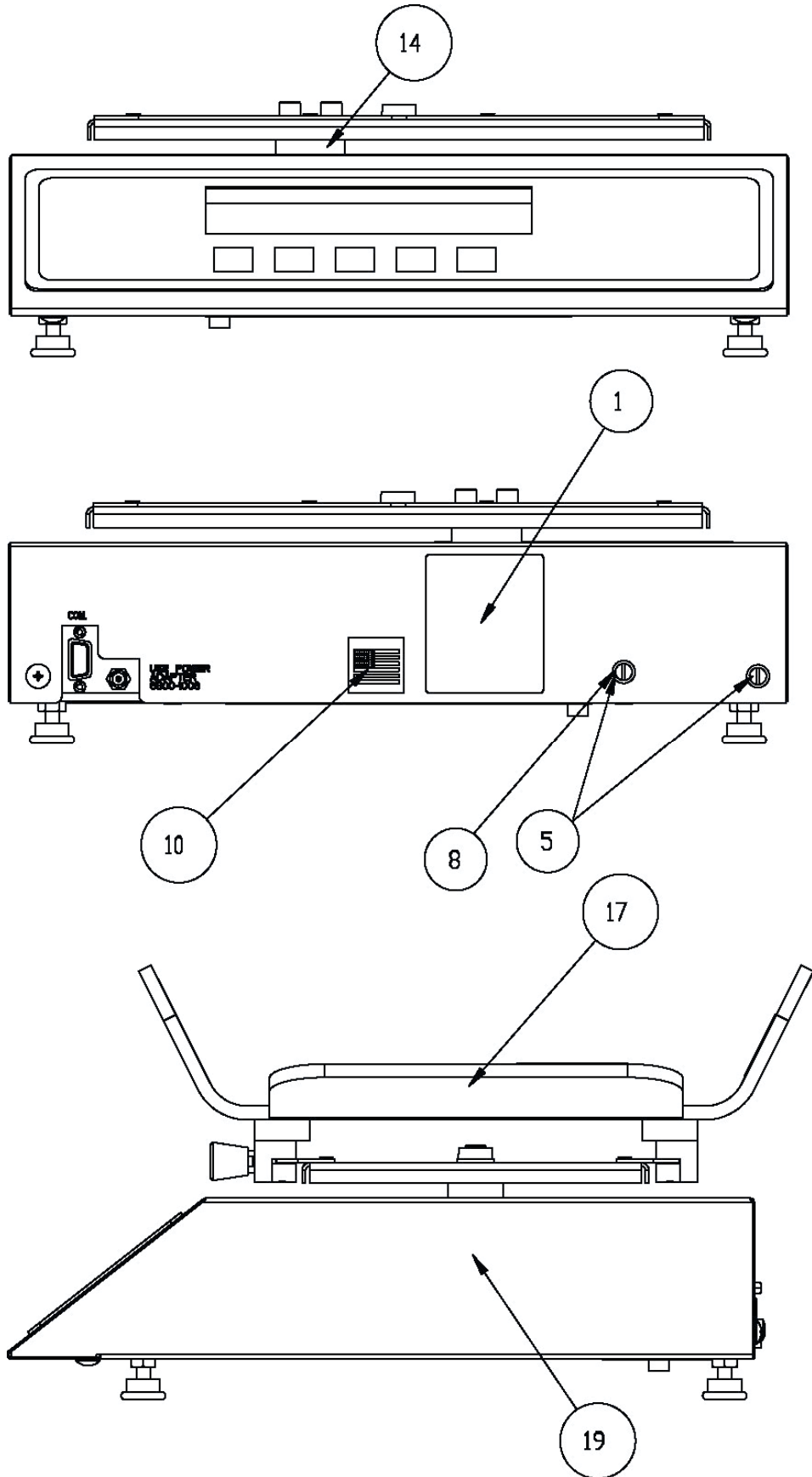

PART IDENTIFICATION, Cont.

ITEM NO.	QTY	PART NUMBER	DESCRIPTION
1	1	593GR986	SERIAL TAG
2	1	593R1007	FACTORY SET LABEL
3	3	6021-1058	SCW TRUSS HEAD MACH-SCW 10-32 X .375
4	1	6021-1103	SCW HALF-DOG. SET SCREW #8-32 X .50
5	2	6021-1108	SCW FILLISTER MACH-SCW #10-32 X .375 S.S.
6	2	6021-1554	SCW SOCKET HD CAP SCW .025-20 – 1.50D
7	2	6024-0039	WASHER LOCK HELICAL 1/4 REG.
8	5	6024-1010	WASHER LOCK INT-TOOTH #10 Z/PL.
9	1	6560-1072	ADHESIVE, LOCTITE
10	1	6650-0087	LABEL: MADE IN THE USA
11	8	6680-0173	POP RIVET
12	1	6690-0001	BUBBLE LEVEL
13	2	8535-B060-08	BABY TRAY RECEIVER
14	1	8535-B062-08	LOAD CELL SPACER
15	1	8535-B065-08	WARNING LABEL – BABY SCALE
16	1	8535-B067-0A	WEIGHBRIDGE WELDMENT
17	1	8535-C066-0A	BABY TRAY ASSEMBLY
18	1	8535-D045-08	KEYPAD
19	1	8535-D053-08	COVER
20	1	8535-D058-0A	BASE ASSEMBLY

