

This document hosted by
OldWillKnottScales
~ ~ CLICK HERE ~ ~
to visit us the next
time you need a scale!

Operating Manual

Electronic Platform & Bench Scale CTB Series



Table of Contents

SECTION 1 INTRODUCTION.....	1
SECTION 2 SPECIFICATIONS.....	2
SECTION 3 INSTALLATION.....	3
SECTION 4 KEY DESCRIPTIONS.....	4
SECTION 5 DISPLAYS.....	5
SECTION 6 OPERATION.....	6
6.1 Zeroing the display.....	6
6.2 Taring.....	6
6.3 Weighing a sample.....	6
6.4 Parts counting.....	6
6.5 Check-weighing.....	7
6.6 Accumulated total.....	8
6.7 Net/gross change.....	8
SECTION 7 PARAMETERS.....	9
SECTION 8 BATTERY OPERATION.....	11
SECTION 9 RS-232 OUTPUT.....	12
SECTION 10 CALIBRATION.....	13
SECTION 11 TECHNICAL PARAMETES.....	14
SECTION 12 TROUBLE SELF-CHECKING.....	15
SECTION 13 TROUBLESHOOTING.....	16
13.1 No power.....	16
13.2 No display.....	17
13.3 Can't charge the battery.....	18
13.4 Can't weighing.....	19
13.5 Reading jump.....	20
13.6 Keyboard can't work.....	20

SECTION14 CHANGE PARTS PROCESS.....	21
14.1 Replace main board.....	21
14.2 Replace load cell.....	21
14.3 Replace MPU.....	22
14.4 Replace battery.....	22
SECTION15APPENDIX.....	23
15.1 Schematic (main).....	23
15.2 Schematic (display).....	24
15.3 Parts drawing.....	25
15.4 Parts list.....	26
15.5 Error codes.....	27
15.6 Numeric and alphabetic characters displayed on LCD.....	27

SECTION 1 INTRODUCTION

The CTB series of bench scale provides an accurate, fast and versatile series of general purpose weighing scale with counting and check-weighing functions.

There are 3 series scales within the range, the platform size from 420mm x 520mm , the capacity range from 150lb to 600lb.

All the keypads are sealed, color coded membrane switches and the displays are large easy to read liquid crystal type displays (LCD). The LCD's are supplied with a backlight.

All units include automatic zero tracking, audible alarm for pre-set weights, automatic tare, and an accumulation facility that allows the individual weights to be stored and recalled as an accumulated total.

SECTION 2 SPECIFICATIONS

Model	CTB-150	CTB-300	CTB-600
Platform size	420mm x 520mm	420mm x 520mm	420mm x520mm
Capacity	150lb	300lb	600lb
Resolution	1:3000		
Interface	RS-232 Output Optional (standby)		
Stabilisation Time	1 Seconds typical		
Operating Temperature	5°C - 35°C / 41°F - 95°F		
Power supply	External AC adapter, 9V 800mA		
Calibration	Automatic External		
Display	6 digits LCD digital display with 24mm high digits		
Balance Housing	Indicator ABS Plastic		
Load cell drive voltage	Max 5V/150mA		
Load cells	Up to four 350 ohms cells		

SECTION 3 INSTALLATION

GENERAL INSTALLATION

The scales should be sited in a location that will not degrade the accuracy.

Avoid extremes of temperature. Do not place in direct sunlight or near air conditioning vents.

Avoid unsuitable tables. The tables or floor must be rigid and not vibrate. Do not place near vibrating machinery.

Avoid unstable power sources. Do not use near large users of electricity such as welding equipment or large motors.

Avoid high humidity that might cause condensation. Avoid direct contact with water. Do not spray or immerse the scales in water.

Avoid air movement such as from fans or opening doors. Do not place near open windows.

Keep the scales clean.

Do not stack material on the scales when they are not in use.

INSTALLATION OF CTB SERIES

The pillar is attached to the base using a bracket that must first be attached to the base frame using the 4 bolts supplied. The Pillar is secured to the bracket using 2 set screws. The cable from the base to the indicator module is run through the tube, out through the plastic support at the top. Excess cable can be stored within the tube.

The CTB Series comes with a stainless steel platform packed separately. Place the platform in the base.

Level the scale by adjusting the four feet. The scale should be adjusted such that the bubble in the spirit level is in the centre of the level and the scale is supported by all four feet. If the scale rocks readjust the feet.

Attach the indicator module to the pillar by sliding it over the bracket with the flanges engaged in the groves on the base.

Attach the AC power adapter to the connector on the back of the indicator.

SECTION 4 KEY DESCRIPTIONS

Zero or

Set the zero point for all subsequent weighing. The display shows zero.

A secondary function , of "Enter" key when setting parameters or other functions.

Tare or

Tares the scale. Stores the current weight in memory as a tare value, subtracts the tare value from the weight and shows the results. This is the net weight. Entering a value using the keypad will store that value as the tare value.

A secondary function , of incrementing the active digit when setting a value for parameters or other functions.

Smpl or

Enter counting mode from weighing mode. Shift unit weight, counts and total weight when counting mode. Move the active digit right when setting values for other functions.

The second function, when the scale self-check press the key, it will show "CAL X", it is an arithmometer (COUNTER) for the times of calibration is successful.

N/G

Used to select the weight model of the scale. If the scale has tared, switch to the mode of net weight or gross weight. Move the active digit left when setting values for other functions.

The second function, when the scale self-check press the key, it will show "opt X", it is an arithmometer (COUNTER) for the times of parameter setting.

Func or F

Used to select the function of the scale. If the scale is weighing it will select parts counting. Of it is not in weighing mode it will return the user to weighing.

Secondary function (C) , is to act as a clear key when setting values for parameters or other functions.

Print or

To print the results to a PC or printer using the optional RS-232 interface. It also adds the value to the accumulation memory if the accumulation function is not automatic.

Secondary function (ESC) , is to return to normal operation when the scale is in a parameter setting mode.

ON/ OFF or

Turn on or off the power.

SECTION 5 DISPLAYS

The LCD display will show a value and a unit to the right of the digits.
 In addition there are labels for TARE, GROSS weight, Zero and for Low battery

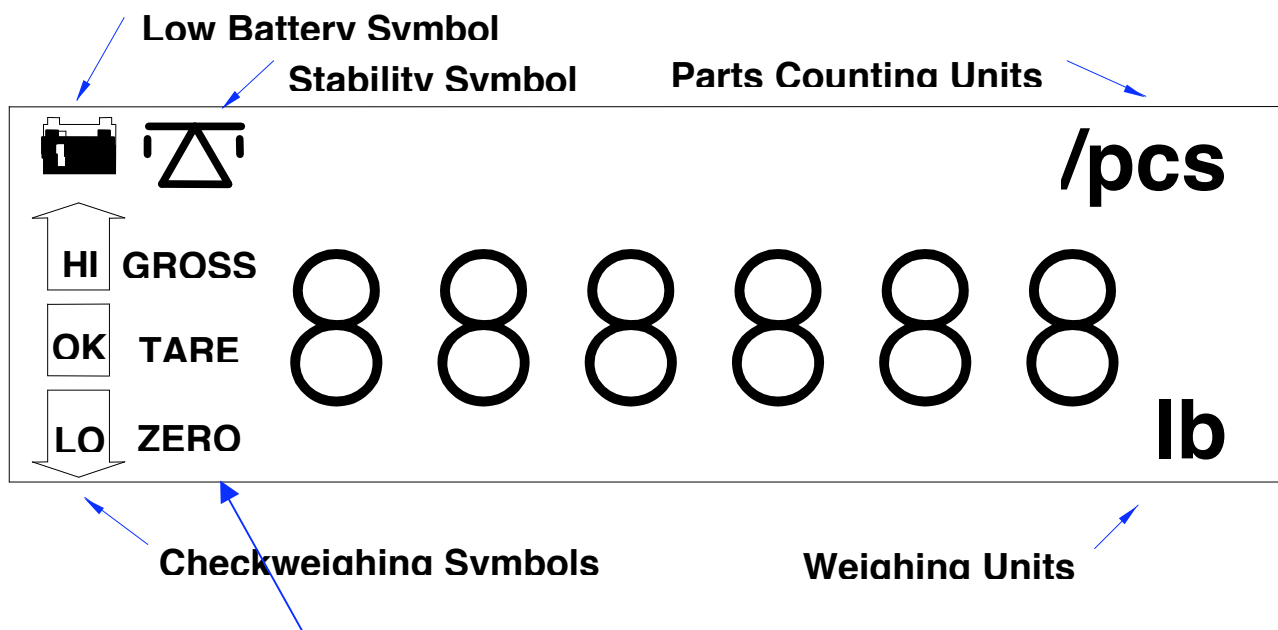

Center of Zero Indication

SECTION 6 OPERATION

6.1 Zeroing The Display

You can press the ZERO/ENTER key at any time to set the zero point from which all other weighing and counting is measured, within set % in 0-Range parameter from power up zero. This will usually only be necessary when the platform is empty.

When the zero point is within "CENTRE OF ZERO" range display will show the indicator for "zero".

The scale has an automatic rezeroing function to account for minor drifting or accumulation of material on the platform. However you may need to press the ZERO/ENTER key to rezero the scale if small amounts of weight are shown when the platform is empty.

6.2 Taring

Zero the scale by pressing the ZERO/ENTER key if necessary.

Place a container on the platform, a value for its weight will be displayed.

Press the TARE key to tare the scale. The weight that was displayed is stored as the tare value and that value is subtracted from the display, leaving zero on the display. The "TARE" indicator will be on. As product is added only the weight of the product will be shown. The scale could be tared a second time if another type of product was to be added to the first one. Again only the weight that is added after taring will be displayed.

When the container is removed a negative value will be shown. If the scale was tared just before removing the container this value is the gross weight of the container plus all product that was removed. The zero indicator will also be on because the platform is back to the same condition of "CENTER OF ZERO" range.

6.3 Weighing a sample

To determine the weight of a sample first tare the empty container then place the sample in the container. the display will show the weight and the units of weight currently in use.

6.4 Parts Counting

When the scale is showing weight, pressing the SMPL key will start the parts counting function.

Before beginning, tare the weight of any container that will be used, leaving the empty container on the scale. Place the number of samples on the scale. The number should match the options for parts counting, 10, 20, 50, 100 or 200 pieces.

Press the SMPL key to begin. The scale will show "SP 10" asking for a sample size of 10 parts. Change the sample size by pressing the TARE/↑ key. the display will cycle through the options: 10,20, 50, 100, 200 and back to 10.

Press the SMPL key when the number matches the number of parts used for the sample. As more weight is added the display will show the number of parts (pcs).

Press the FUNC key to return to normal weighing.

6.5 Check-Weighing

6.5.1 About check-weighing

Check-weighing is a procedure to cause an alarm to sound when the weight on the scale meets or exceeds values stored in memory. The memory holds values for a high limit and a low limit.

Check range:

set hi-limit and low-limit as different value, also hi-limit value is larger than low-limit.

Check key point:

set hi-limit and low-limit as same value.

Check mode 2:

When check range, the display will show OK and the beeper will sound when the weight is between the limits.

When check key point, the display will show Ok and the beeper will sound when the weight is under the limits.

Check mode 3:

When check range, the display will show OK and the beeper will sound when the weight is out of the limits.

When check key point, the display will show Ok and the beeper will sound when the weight is over the limits.

6.5.2 Set limits

Press F key, it will display "F0 H-L", press ZERO key to enter, use TARE key to select "SET HI" or "SET LO", press ZERO key to enter, use SMPL key to move active digit, use TARE key to change value, use F key to clear value. After you enter the value, press ZERO key to sure, press Print/M+ key to escape.

6.5.3 Set check weighing mode

Press F key to enter setting mode, press TARE until display show "F4 OFF", press ZERO key to enter, press TARE key until display show "BEEP", press ZERO key to enter, press TARE key to select BP 2(check mode 2), BP3 (check mode 3), BP1(not sound), press ZERO key to sure, press PRINT/M+ key to escape.

6.5.4 NOTE

The weight must be greater than 20 scale divisions for the check weighing to operate.

To disable the Check-Weighing function enter zero into both limits by pressing the FUNC key when the current limits are shown then pressing ZERO/ENTER to store the zero values.

6.6 Accumulated Total

The scale can be set to accumulate manually by pressing the PRINT key. See the PARAMETERS Section for details of selecting the method using function "F5 P RT". The accumulation function is only available when weighing. It is disabled during parts counting.

The weight displayed will be stored in memory when the PRINT key is pressed and the weight is stable.

The display will show "ACC 1" and then the total in memory for 2 seconds before returning to normal. If the optional RS-232 interface is installed the weight will be output to a printer or PC(this type machine has no print function).

Remove the weight, allowing the scale to return to zero and put a second weight on. Press the PRINT key, the display will show "ACC 2" and then the new total.

Continue until all weights have been added.

To view the totals in memory press enter the PARAMETER SECTION and use function "F1 TOL". See below.

6.7 Net/gross change

When you weigh, press N/G key , you can check net weight and gross weight.

SECTION 7 PARAMETERS

The scale has 6 parameters that can be set by the user plus a method of entering the calibration section.

To set parameters press the FUNC key.

The display will show the first function, "F0 H-L".

Pressing the TARE/+ will cycle through the other functions.

Pressing ZERO/ENTER will allow you to set the function. It may be necessary to either use TARE/+ or set a value using the SMPL/→ key to move the active digit and then using the TARE/↑ key to increment a digit, followed by the ZERO/ENTER key to enter the value. Use the PRINT/ESC key to leave a parameter unchanged.

For example when the display shows "F0 H-L" press the ZERO/ENTER key to begin.

The display will show "Set Lo", press the ZERO/ENTER key to set the low limit, or press the TARE/+ to skip to the next parameter, "Set Hi" for setting the high limit.

After pressing the ZERO/ENTER key to set a limit, use the the SMPL/→ keys to change the flashing digit, then use the TARE/↑ key to increment the flashing digit. Continue to the next digit and set it as needed.

When all digits have been set press the ZERO/ENTER key to store the value. The display will go back to the parameter just set, i.e. "Set Lo". Advance to another parameter if needed or press the PRINT/ESC key to return to weighing.

FUNCTION MENU SETTINGS

FUNCTION	SUB-FUNCTION	DESCRIPTION	DEFAULT VALUE
F0 H-L	SEt Lo	Set a value for the Low limit.	000.000
	SEt HI	Set a value for the High Limit.	000.000
F1 toL	to CLr	Clears the accumulation memory without printing the results.	
	to P-C	Prints the Accumulation memory total and then clears the memory.	
	to Prt	Prints the Accumulation Total, does not clear the memory.	
F2 off	bL	Set the backlight to be on, automatic or off, EL on EL Au EL off	EL Au
	beep	Set the beep mode.(check weighing mode 2, check weighing mode3, no beep)	
	sleep	Set the time of automatic sleep: 1,5,10,30 or OFF	10
Prog	Pin	Enter the programming and calibration menus by entering the correct password. See the section 11.	

SECTION 8 BATTERY OPERATION

The weighing indicator can be operated from the battery if desired. The battery life is approximately 100 hours.

When the battery needs charging a symbol on the weight display will turn on. The battery should be charged when the symbol is on. The scale will still operate for about 10 hours after which it will automatically switch off to protect the battery.

To charge the battery simply plug into the mains power. The scale does not need to be turned on.

The battery should be charged for 12 hours for full capacity.

Just under the quantity display is an LED to indicate the status of battery charging. When the scale is plugged into the mains power the internal battery will be charged. If the LED is green the battery has a full charge. If it is Red the battery is nearly discharged and yellow indicates the battery is being charged.

As the battery is used it may fail to hold a full charge. If the battery life becomes unacceptable then contact your distributor.

SECTION 9 RS-232 OUTPUT (optional)

The CTB Series of scales can be ordered with an optional RS-232 output.

Specifications:

RS-232 output of weighing data
 ASCII code
 8 data bits
 No Parity

Connector: 25 pin d-subminiature socket

Pin 2: Output

Pin 3: Input, not used at this time

Pin 5: Signal Ground

Data Format for normal weighing operations, parts counting or recalling of totals from memory will all be different. Examples follow:

Normal Output

GS	12.340kg	GS for Gross weight, NT for net weight and a unit of weight
No..	1	This number increments every time a new value is stored in memory
Total	12.340kg	The total value stored in memory
<lf>		Includes 2 line feeds
<lf>		

When parts counting the weight, unit weight and count will be printed.

GS	12.340kg	GS for Gross weight, NT for net weight and a unit of weight
U.W.	123.4g/pcs	The average piece weight computed by the scale
PCS	100pcs	The number of parts counted
<lf>		Includes 2 line feeds
<lf>		

When recalling the Total weight stored in the accumulation memory the output format is:

*****	A line of stars is shown
<lf>	Includes 1 line feed
TOTAL	
No. 5	
Wgt 21.455kg	

SECTION 10 CALIBRATION

Turn the power off. During the counting from 9 to 0 press the FUNC/C key.

The display will show "CAL " for a few seconds. While it is showing "CAL " press the UINT , PRINT and TARE keys in sequence to enter the Calibration section. The display will show "unLoAd".

Remove any weight from the platform. Press the ZERO/ENTER key.

The display will show "LoAd". Place the calibration weight on the scale. Press the ZERO/ENTER key.

If the calibration weight is right, the display will show "PASS", If the calibration weight is unapt, the display will show "FAIL H" or "FAIL L". the calibration is not acceptable.

If the calibration is acceptable the display will return to normal. If an error message is shown try calibration again as a disturbance may have prevented a successful calibration.

If the problem persists then contact your dealer.

SECTION 11 TECHNICAL PARAMETERS

Press F key when normal weighing mode, display shows "F0 H-L", press TARE key until display shows "P ROG", press ZERO key, display shows "PIN", You can press **unit** PRINT TARE key to enter setting mode, press Tare key to select parameter, press Zero key to sure, press Print key to escape. Before you set parameters, please short the K1.

FUNCTION	SUB-FUNCTION	DESCRIPTION
----------	--------------	-------------

P1 REF	AZN 0	This option is used to select the auto zero tracking. Options : 0.25d, 0.5d,
	0-AUTO	This option is used to select the Initial zero setting range (mechanism) when turn the indicator. Options : 0%, 2%, 5%, 10%, 20%
	0- RANGE	This option is used to select the (SAZSM) manual zero range when press the ZERO key. Options: 2%, 4%, 10%, 20%,
P 2 CAL	C AP	This display will show xxxxxx for setting the capacity.
	CAL	Calibrate, see detail in section 10.
	CNT	This display will show xxxxxx for indicating the internal counts.
P3 P RT	P-AUTO	Automatic print setting, when the weight is stable, the data will be printed automatic
	P-PRT	Manual print setting, when the weight is stable, press the PRINT key, the data will be printed.
	P cont	Connect PC, the data will be send to PC

AUDIT TRAIL COUNTER :

CALIBRATION:

When the scale self-check press the SMPL/  key, it will show "CAL X", it is an Audit trail counter for each Successful CALIBRATION.

PARAMETER (OPERATIONAL) COUNTER :

When the scale self-check press the N/G key, it will show "opt X", it is Audit trail counter for any change in parameter setting.

SECTION 12 TROUBLE SELF CHECKING

Problem	Possible cause	Common solutions
Display is blank, No turn on test	Mains power is turned off Power supply not plugged in Power supply faulty Internal battery not charged Display turned off	Check power is going to the scale and switch is on. Verify the voltage going to the scale matches the power supply labels on the power module or scale.

Display blank after turn on test, Error message Display is locked	Pan not installed Unstable weight Load cell damaged Mechanics damaged	Check the pans are installed correctly. Try turning the scale on again.
OL or FULL appears on display	Maximum capacity exceeded Load Cell or mechanics damaged Power supply faulty	Check the pans are installed correctly. Try turning the scale on again.
UL or NULL displayed	Weight on scale below permissible limit Pan has been removed Pan support not seated properly Power supply faulty Load Cell or mechanics damaged	Check the pans are installed correctly. Try pressing Zero key. Try turning the scale on again.
Display is unstable	Drafts or air currents Obstruction under pan Sample is moving (animal weighing) Vibrations through table Temperature changed dramatically Power supply faulty	Verify the scale is in a acceptable location and on a good table. Verify the power supply is correct for the scale.
Weight value incorrect	Calibration error, Recalibrate Linearity error, set Linearity Unit calibrated with inaccurate weight Balance not level Obstruction between sample and cover Wrong unit of weight displayed	Calibrate again, paying special attention to the mass used, the stability of the scale, and the weighing units required. If linearity can be set by the user it will be described in the user manual. Check pan is installed correctly. Verify installation is acceptable.
Cannot use Full Capacity	Over load Stops hitting pan support or hitting bottom of load cell Shipping screw not removed if applicable Electronic problem on A/D Parameters set incorrectly Load Cell or mechanics Damaged	Look for obstruction under pan, shipping screws, and verify pan installation. Check the weighing units used.
Not Linear	Overload stops hitting too soon Load cell or mechanics damaged A/D damaged	Look for obstruction under pan, shipping screws, and verify pan installation. If linearity can be set by the user it will be described in the user manual.
Off Center	Adjust mechanics	Look for obstruction under pan,

Loading error	Overload Stops not correct Load Cell damaged	shipping screws, and verify pan installation.
Battery will not charge	Mains voltage not present or too low Charging circuit failure Battery Failure	Verify the batteries are rechargeable types. Check power supply voltage is correct.

SECTION 13 TROUBLESHOOTING

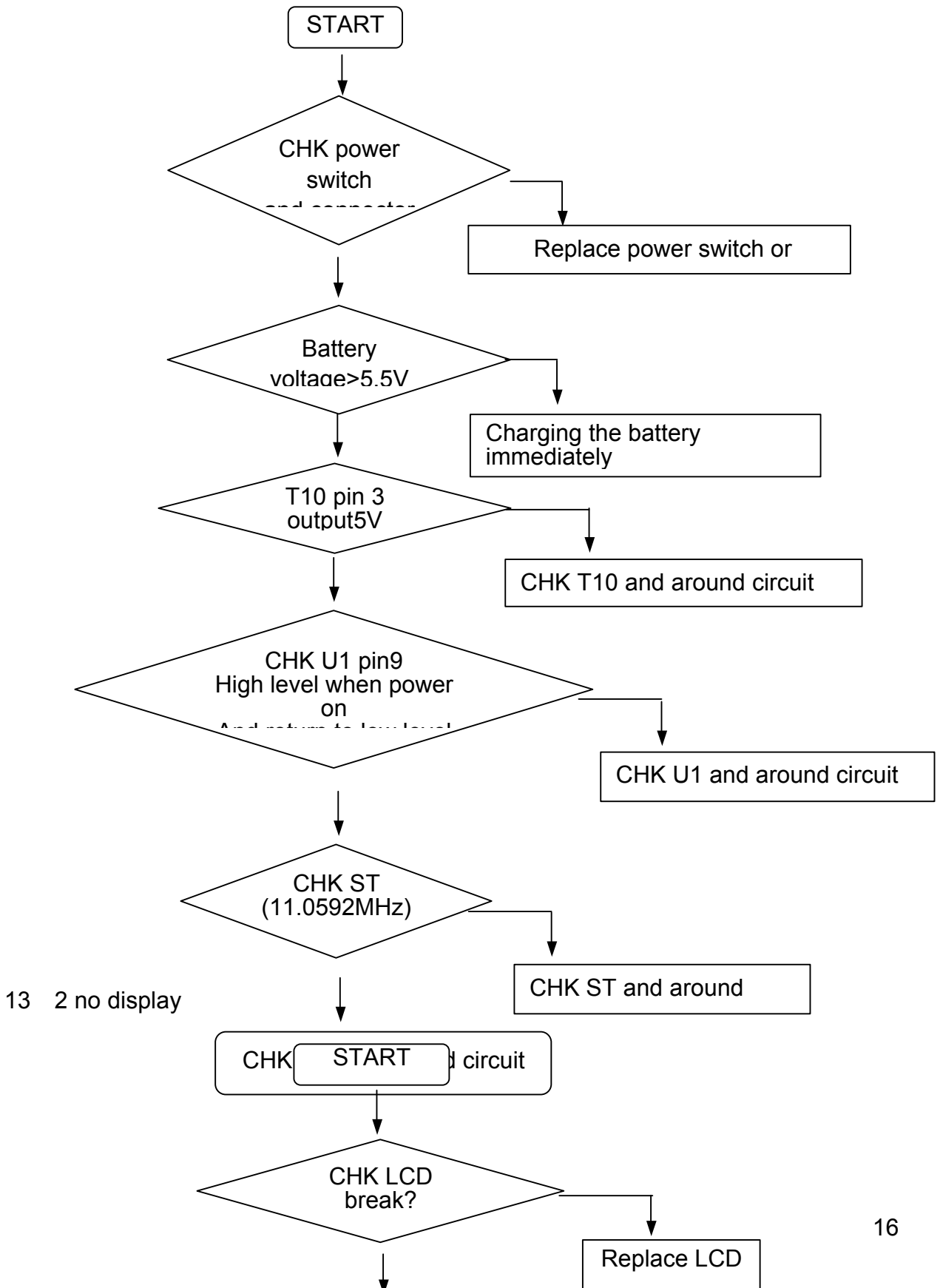

13 3 Can't charge the battery

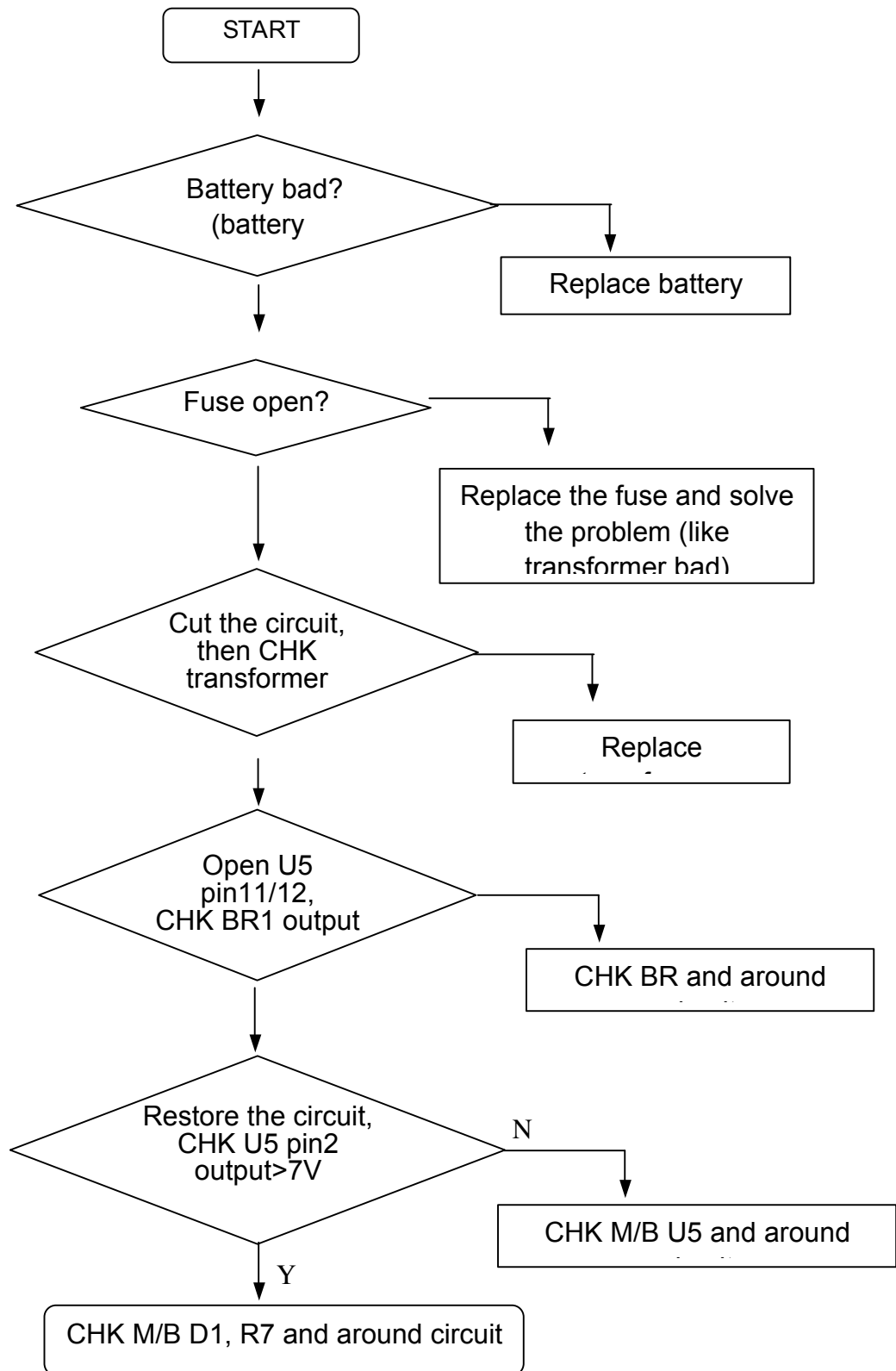

13 4 Can't weigh

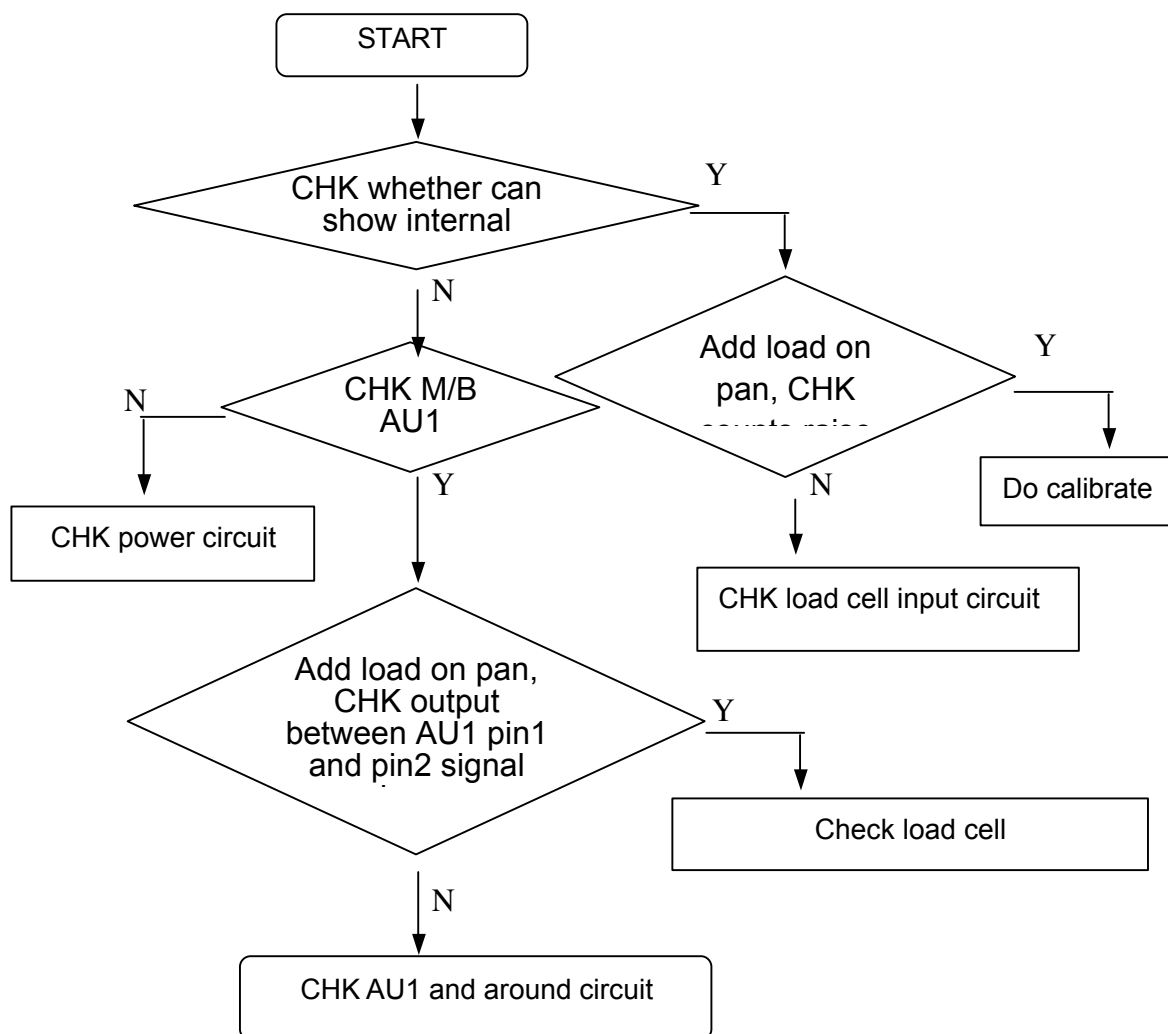

13 5 unstable

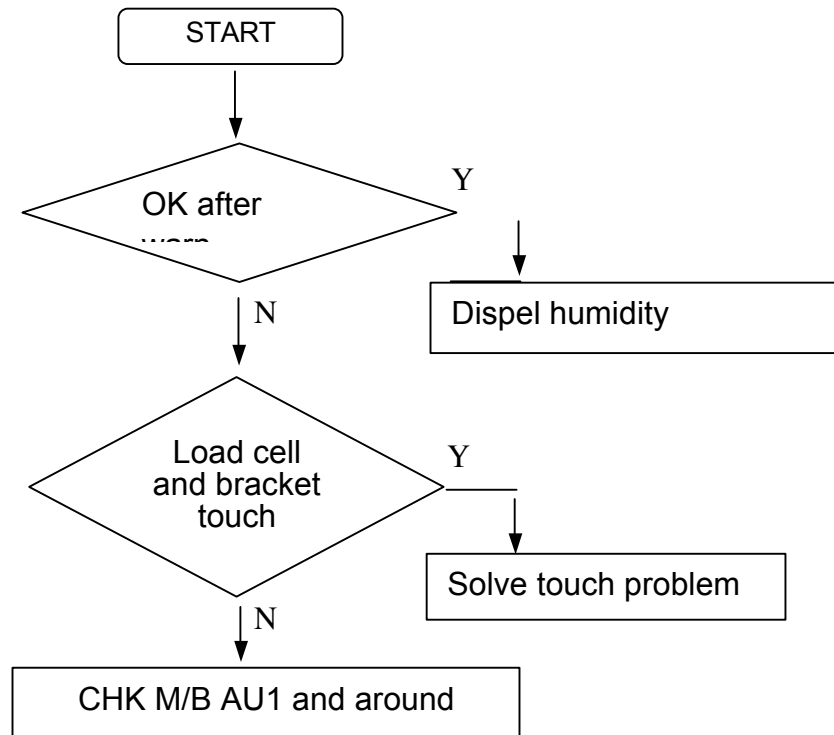

13 6 Can't use keyboard

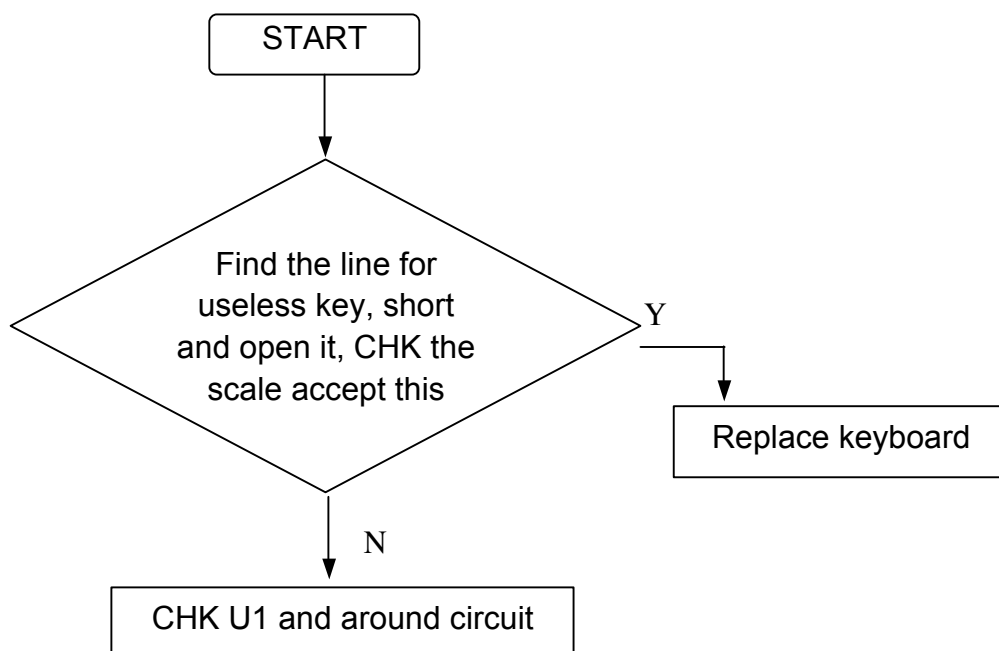

Note: M/B means main board, D/B means display board.

SECTION 14 CHANGE PARTS PROCESS

14 1 Replace main board



At first, release indicator from indicator bracket, like picture, then release 6 pcs screw from back cover of the indicator use cross



screw driver. Then, open the back cover, release 4 pcs screw of main board, release main board carefully, pull out all



connector on the main board, out main board carefully. Then board, plug all connector at last ATTENTION CH3.96



then you can bring install the new main 4P connector (for

power) must be pulled out at first and plug at last After check anything try to turn on the power if anything is OK close the back cover replace main board completely.

14 2 replace load cell



At first, use internal hexagon screw driver release 4 pcs screw from upper bracket, remove upper bracket, then release 4 pcs screw from bottom



bracket, by this way, you can remove load cell now. Use iron to solder cable for load cell, remove cable from connector, then pull cable from pole. Bring new load cell, let cable through pole, solder the cable to



connector. Now, you can fix 8 pcs internal hexagon screw again (Attention: fix tight enough as you can). Then you can check and adjust corner and overload stop use file and internal hexagon screw driver. After check anything, try to turn on the power and show the internal counts, if internal counts looks OK, close the pan, change load cell completely.

14 3 replace MPU



At first, release indicator from indicator bracket, like picture, then release 6 pcs screw from back cover of the indicator use cross screw driver. Then, open the back



cover, pull of the connector for power (CH3.96 4P), use special IC kit or minus screw driver to put up the MPU from DIP40 socket

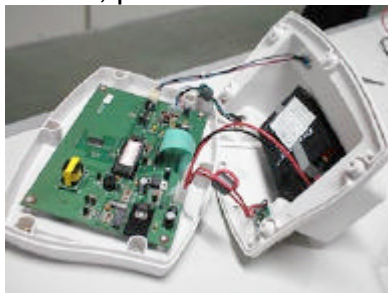

(Attention: please don't let the IC pin tilt), then use the new MPU plug into DIP40 socket (Attention: please note the gap direction), after



check anything is OK, plug the power connector (CH3.96 4P), try to turn on the power, if scale work correctly, replace MPU completely.

14 4 replace battery

At first, release 4 pcs screw of the battery cover. use cross screw driver, Then, open the battery cover, you can bring the battery from scale,

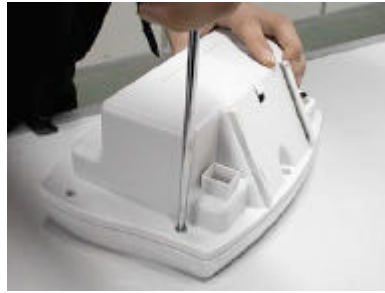

use iron solder off wire, bring new battery, use iron to solder the battery, (Attention: red line to positive electrode, black line to minus electrode), after check anything, plug the connector for power and try to turn on the power, if scale work correctly, replace battery completely.

SECTION15 APPENDIX

15.1 SCHEMATIC (main)

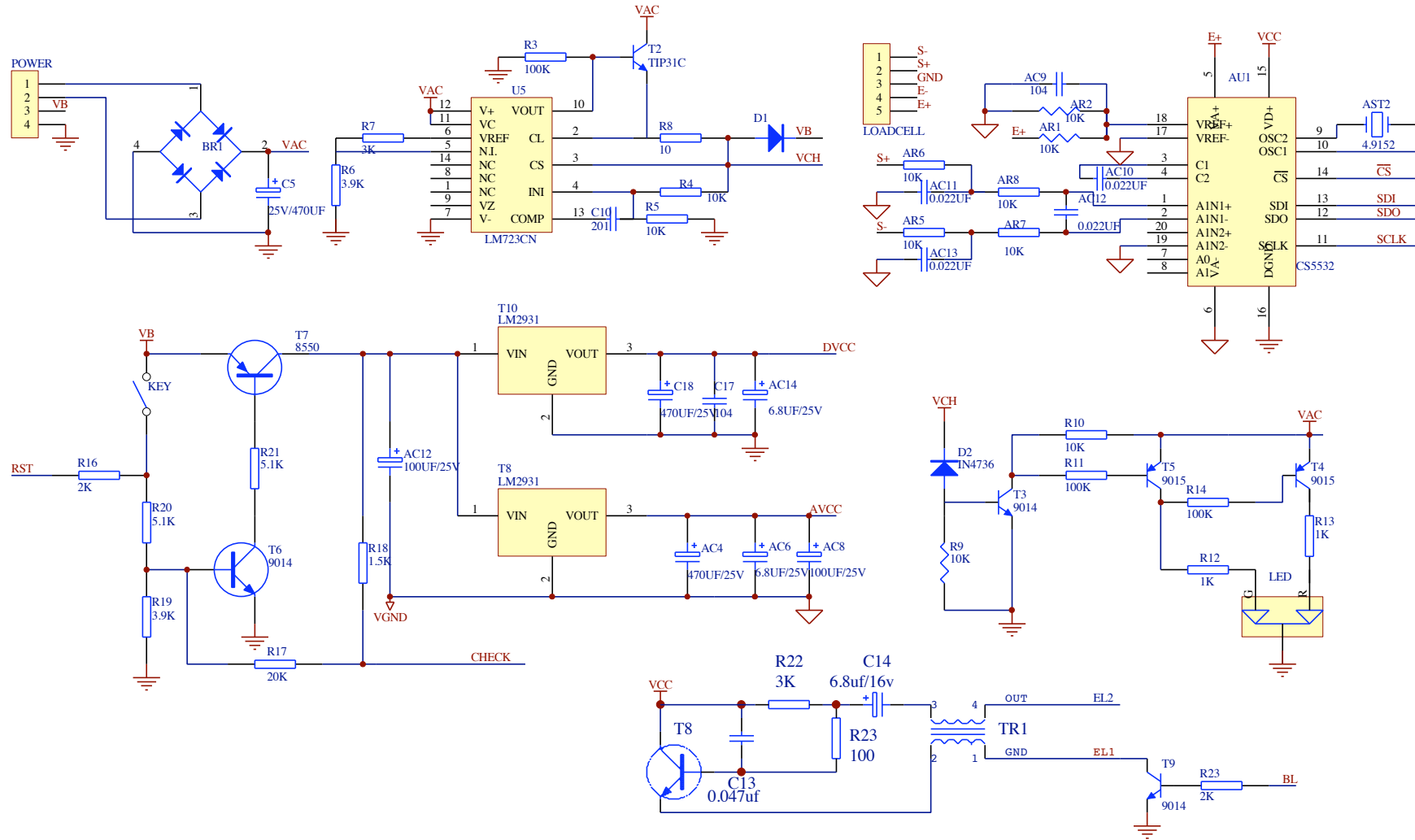

15.2 SCHEMATIC (display)

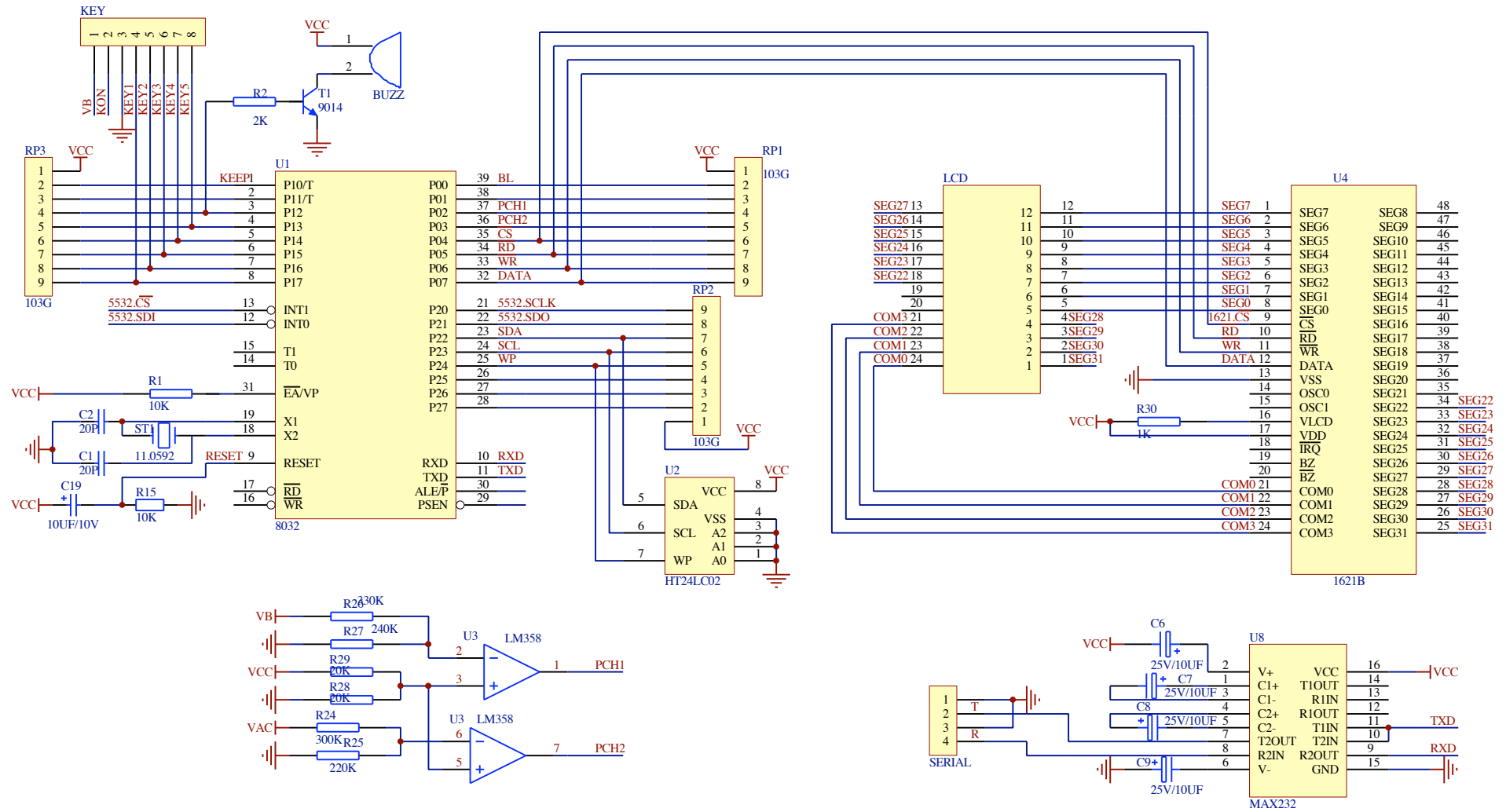

15. 3 PARTS DRAWING

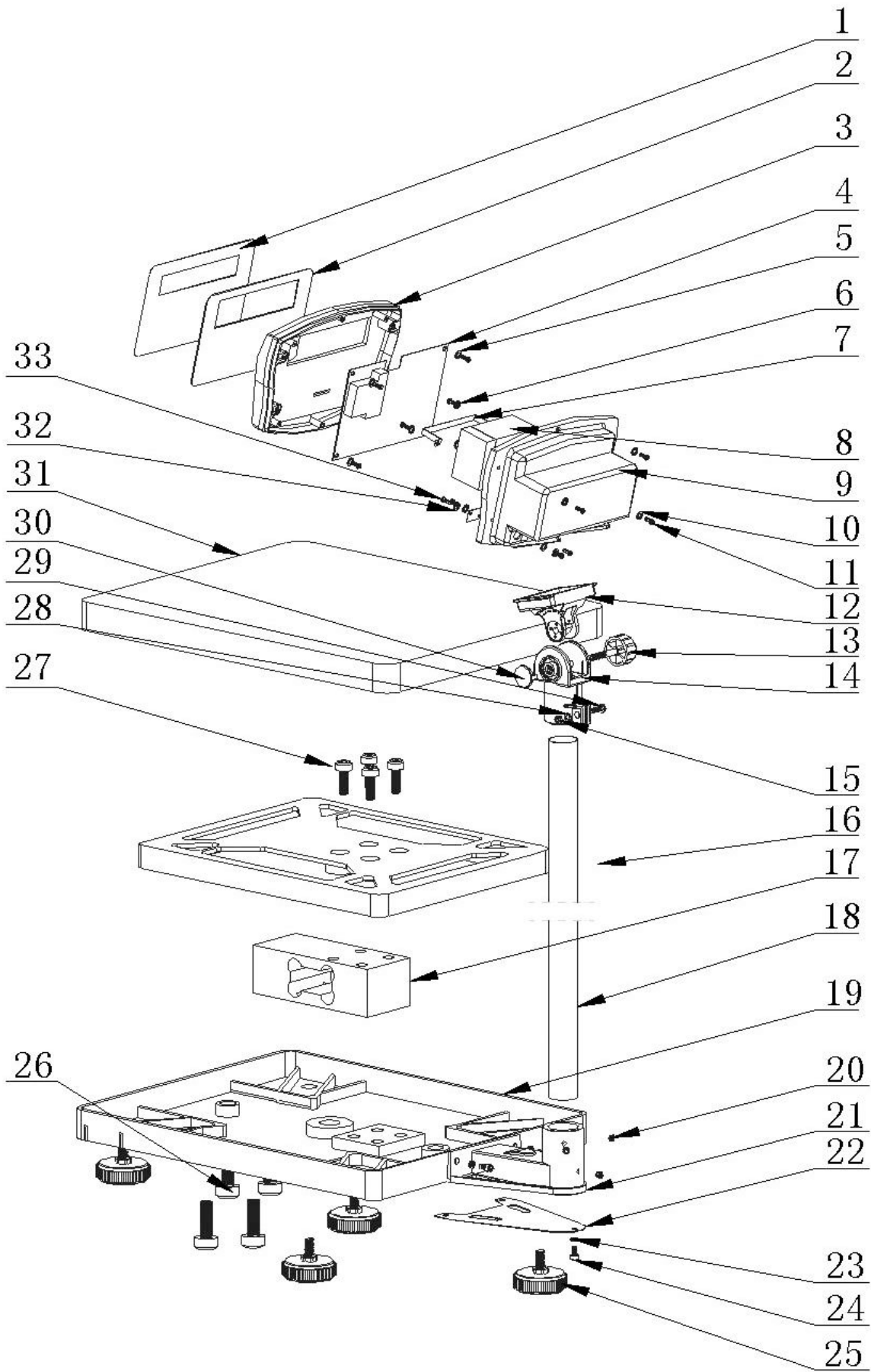

15. 4 PARTS LIST

Parts No.	Parts name	QTY	Material	Spec
1	overlay	1	PC	
2	iron plate	1	iron	
3	Top cover	1	ABS	
4	Main PCBA	1		
5	washer	4	EPDM	
6	screw	4	S18C	M4 x 8
7	Battery holder	1	SUS#304	
8	Battery	1	Lead acid	6V/4Ah
9	Bottom cover	1	ABS	
10	washer	6	EPDM	
11	screw	6	S18C	M4 x 20
12	Neck parts 1	1	ABS	
13	Neck parts 2	1	ABS	
14	Neck parts 3	1	ABS	
15	nut	1	S18C	M6 x 3.5
16	Load cell upper supporter	1	Al	
17	Load cell	1	Al	
18	Pole	1	SST	
19	Bottom bracket	1	Al	
20	Overload stop screw	4	S18C	M8 x 7
21	Pole bracket	Q235		
22	Mat for pole	steel	189 x 132 x 0.8	
23	Spring washer	3	steel	10 x 6 x 2
24	internal hexagon screw	3	35#	M6 x 12
25	feet	4	Rubber	
26	internal hexagon screw	4	35#	M12 x 45
27	internal hexagon screw	4	35#	M12 x 45
28	washer	1	S18C	12 x 7 x 1.2
29	screw	1	S18C	M3 x 20
30	Neck parts 4	1	ABS	
31	pan	1	SST	420 x 520
32	washer	2	EPDM	8 x 3.5 x 1.2
33	screw	2	S18C	M3 x 8

15. 5 ERROR CODES

ERROR CODES	DESCRIPTION	RESOLUTION
- - - - -	Over range	Remove weight from the scale. If the problem persist contact your dealer for assistance.
Err 1	Date Setting Error	Enter date using correct format and reasonable values. Format: yy:mm:dd
Err 2	Time Setting Error	Enter time using correct format and reasonable values. Format: hh:mm:ss
Err 4	Zero Setting Error	The scale was outside the normal zero setting range either when it was turned on or when the ZERO key was pressed. Remove weight from the scale and try again. Use the TARE key to set the display to zero value. If the problem persist contact your dealer for assistance.
Err 6	A/D out of range	The values from the A/D converter are outside the normal range. Remove weight from the scale if overloaded, make sure the pan is attached. Indicates the load cell or the electronics may be faulty. If the problem persist contact your dealer for assistance.
Err 9	Unstable, can't return to zero	When turn on the power, if internal counts is not stable, display will have "Err 9", please check the platform and load cell. If the problem persist contact your dealer for assistance.

15. 6 NUMERIC AND ALPHABETIC CHARACTERS DISPLAYED ON LCD

0	1	2	3	4	5	6	7	8	9
0	1	2	3	4	5	6	7	8	9
A	B	C	D	E	F	G	H	I	J
A	B	C	D	E	F	G	H	I	J
K	L	M	N	O	P	Q	R	S	T
K	L	M	N	O	P	Q	R	S	T
U	V	W	X	Y	Z				
U	V	W	X	Y	Z				

