

# Digital Scale

HL-WP Series

## INSTRUCTION MANUAL

---

HL-1000WP

HL-300WP



HL-3000WP

**AND**

A&D Company, Limited

# SAFETY PRECAUTIONS

All safety messages are identified by the following, “**WARNING**” or “**CAUTION**”, of ANSI Z535.4 (American National Standard Institute: Product Safety Signs and Labels). The meanings are as follows:

 <b>WARNING</b>	A potentially hazardous situation which, if not avoided, could result in death or serious injury.
 <b>CAUTION</b>	A potentially hazardous situation which, if not avoided, may result in minor or moderate injury.

- £ This manual is subject to change without notice at any time to improve the product.
- £ Product specifications are subject to change without any obligation on the part of the manufacture.
- £ When using the HL-WP, the following safety precautions should always be followed.

 **WARNING**    **Use only the specified AC adapter for the scale. Other adapters may cause damage (The AC adapter is optional). Internal service or adjustments to this product should be performed by a qualified person.**

 **CAUTION**    Avoid installing the scale in direct sunlight, which may cause discoloration or malfunctions.

Do not mix the type of batteries. Replace all the batteries at the same time.

If the scale is not to be used for a long period of time, remove all batteries from the battery compartment to avoid leakage.

Avoid overloading that could cause damage to the scale.

Avoid using the weighing pan to move the scale, as that could cause damage to the scale.

When the scale is used with an AC adapter, the scale does not conform to IP-65 protection.

IP 65

↑	Degree of protection against water: Protected against water jets.
↑	Degree of protection against solid foreign objects: Dust-tight.
↑	IP Code (Degree of protection provided by enclosures) of IEC 60529

# PARTS DESCRIPTION

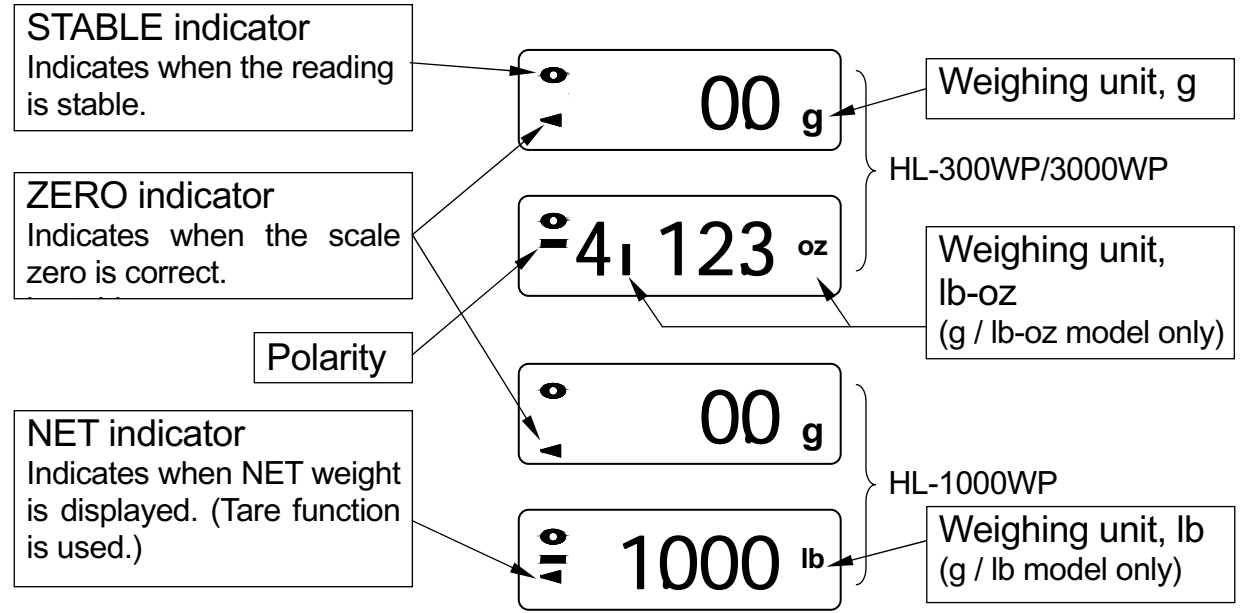
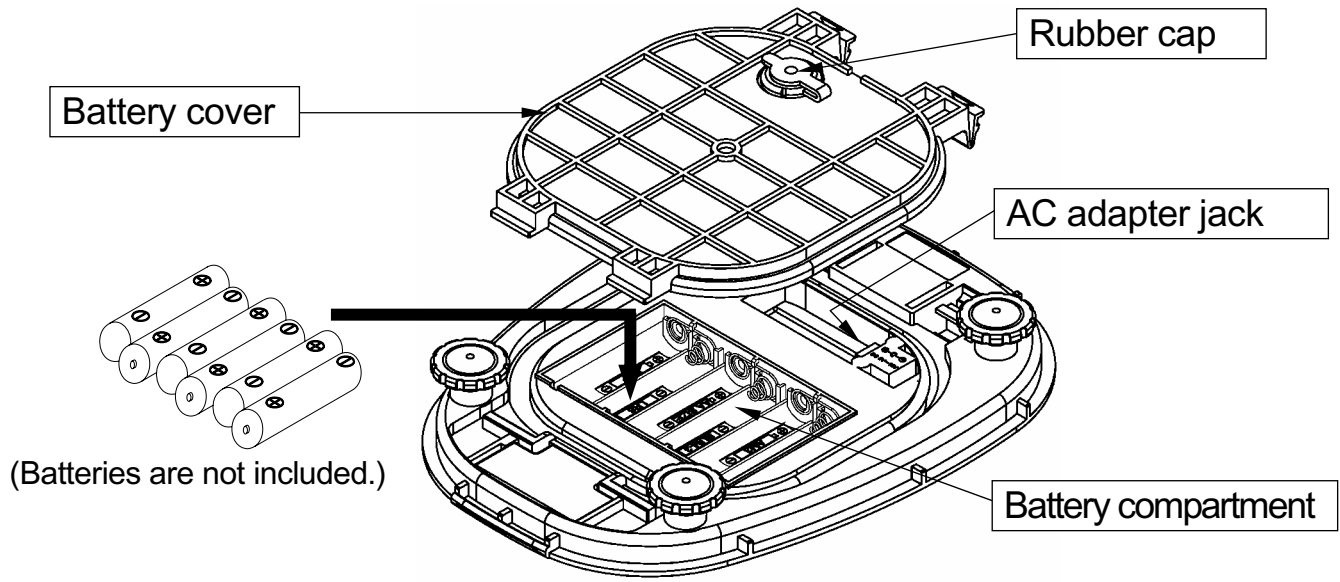
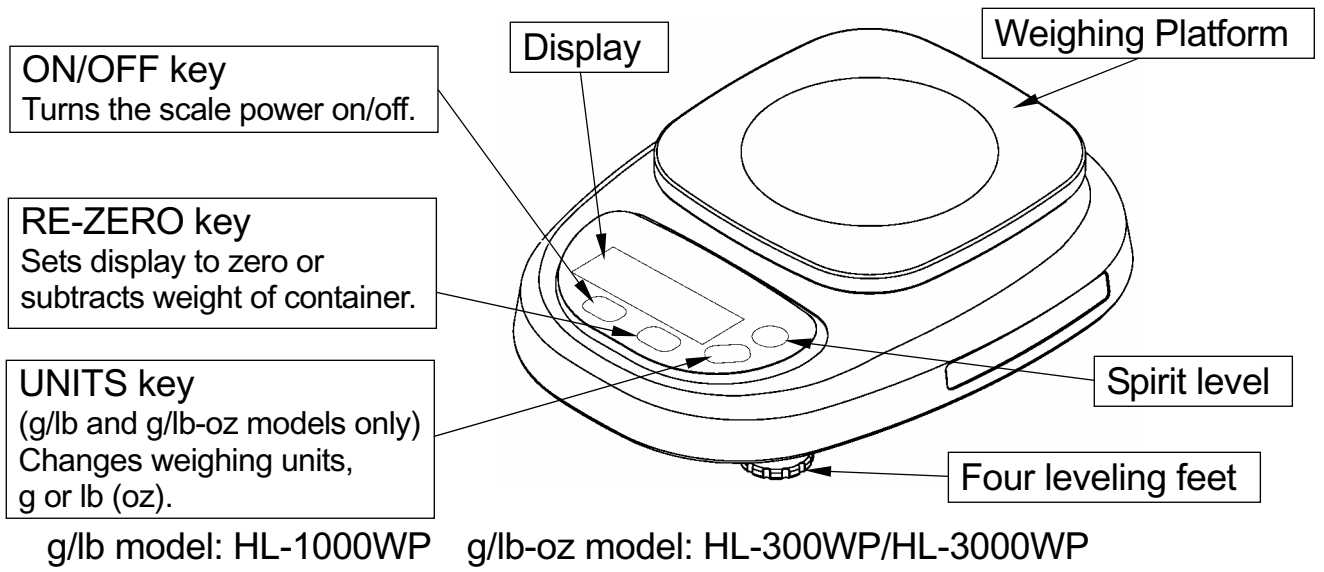

# PREPARATION

## Installing the Batteries / Connecting The AC adapter

### Installing the Batteries

#### ⚠ CAUTION

When replacing batteries, be careful not to apply too much force to the weighing pan. An excessive force could damage the scale.

Remove the battery cover and insert six batteries (R6P / LR6 / AA size) into the battery compartment, taking extreme care to that the polarities plus and minus are observed.

New six batteries (R6P/ LR6/ AA size)

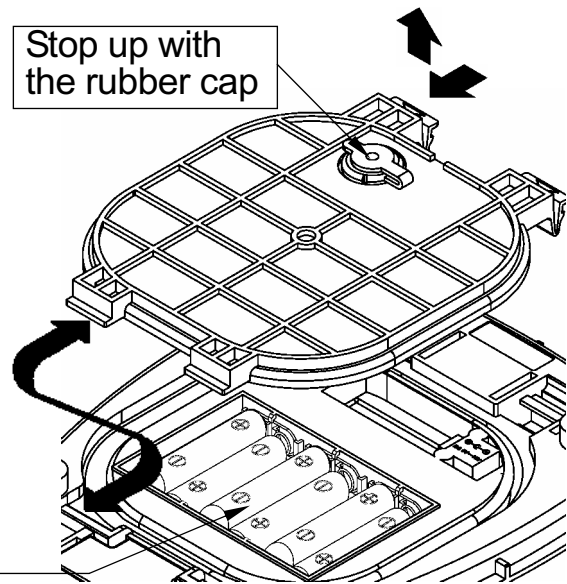

### AC adapter (optional)

#### ⚠ CAUTION

When using an AC adapter, the scale doesn't comply with the IP65.

The AC input requirement could be 100, 120, 220, 230 or 240 volts (50/60Hz) depending on the area where used, so please verify that the adapter is correct.

Plug the AC adapter to the AC adapter socket inside the battery compartment.

Attach the battery cover and fit the rubber cap.

### Optional AC Adapter

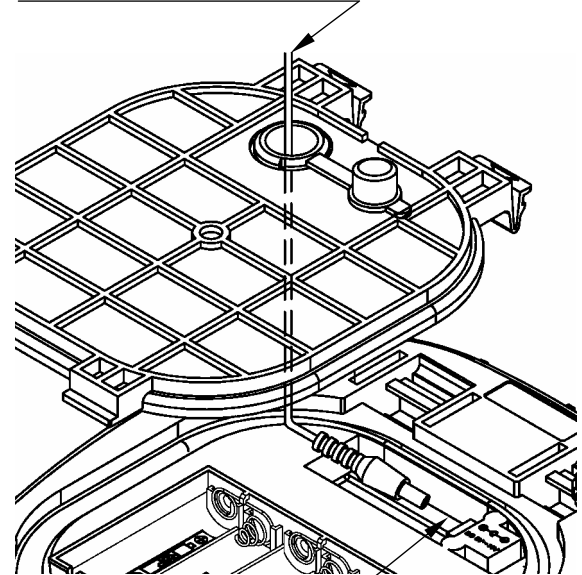

AC Adapter jack

## Setting up the HL-WP

#### ⚠ CAUTION

Avoid installing the scale in direct sunlight, that may cause discoloration or malfunctions. Place your HL-WP on a firm weighing table so that the scale is level. (The scale will not perform accurately when it is not level.)

Place the scale on the firm surface and adjust the feet so that the spirit level shows the scale is level for an accurate weighing.

---

# WEIGHING

---

## Before weighing

### Be aware of the Automatic power-off function.

If this unit is left ON and the stable indicator is displayed, an automatic power-off function turns power off after approximately 5 minutes. To disable this function, press the [ON/OFF] key while pressing the [RE-ZERO] key.

will be displayed and the scale returns to the weighing mode.

### Error message

Overload

The scale zero is out of range

Low battery

### Calibration may be required before weighing

Read "CALIBRATION" first and if necessary, calibrate your scale for accurate weighing.

## Weighing procedures

### 1. Turn on the scale.

Press the [ON/OFF] key to turn on the scale. Then the scale displays all segments for a few seconds and then  will be displayed.

### 2. Start weighing

#### If you do not use a container for weighing,

Verify the reading is . If not, press the [RE-ZERO] key to display . Place objects on the weighing platform to weigh. When the reading becomes stable, the stable indicator is displayed.

#### If you use a container for weighing,

Place an empty container on the platform.

Wait for the stable indicator to be displayed and then press the [RE-ZERO] key. Place the objects to be weighed in the container. When the reading becomes stable, the stable indicator is displayed.

#### Select the weighing unit, --- Only for the "g/lb" or "g/lb-oz" model ---

If you use the "g/lb" or "g/lb-oz" model, press the [UNITS] key to select "g" or "lb", or "g" or "lb-oz" for the weighing unit. Normally scales power up in "lb" or "lb-oz" when shipped from the factory.

To power up with "g" selected:

Turn the scale off. Press and hold the [UNITS] key, then press the [ON/OFF] key. The scale will start with "g". To return to the original setting repeat this instruction.

Note: g/lb model: HL-1000WP

g/lb-oz model: HL-300WP/HL-3000WP

---

# CALIBRATION

---

## When to calibrate

Calibration may be required when the scale initially installed, if it is moved a substantial distance, or in accordance with local regulations. This is necessary because the weight of a mass in one location is not necessarily the same in another location. Also, with time and use, mechanical deviations can occur.

## The position of the [UNITS] key for the Calibration

The g model has no [UNITS] key, but the key used to enter calibration is located under the overlay.

Location of the [UNITS] key

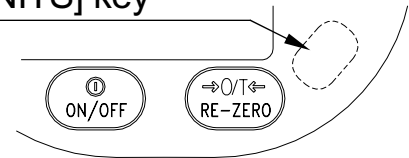

## Calibration using a calibration weight

Calibrate the scale with calibration weights at full capacity.

HL-1000WP: 1000g ± 0.1g  
HL-300WP: 300g ± 0.02g  
HL-3000WP: 3000g ± 0.2g

### 1. Enter calibration mode.

Press the [ON/OFF] key to turn the power off.

While pressing both the [RE-ZERO] key and the [UNITS] key, press the [ON/OFF] key. Cal will be displayed.

### 2. Zero calibration

Press the [RE-ZERO] key to calibrate zero. Cal 0 will be displayed.

Wait for the stable indicator to be displayed and then press the [RE-ZERO] key.

Cal f will be displayed in a few seconds. If only the zero calibration is to be done, press the [UNITS] key. The scale will show end and automatically return to the weighing mode.

### 3. Span calibration

Place the weight at the center of the platform for an accurate calibration. Wait for the stable indicator to be displayed and then press the [RE-ZERO] key. The display will show end and the scale will automatically return to the weighing mode.

# Calibration by gravity compensation

If you have calibration weights at the capacity of the scale, you can calibrate the scale with the weights instead of compensating for acceleration due to gravity.

The scale is calibrated at  $9.798 \text{ m/sec}^2$  at the factory. If the gravity acceleration at your location is not same, calibrate the scale by compensating for the gravity acceleration. (Refer “The Value of Gravity at Various Locations” and “World Map” and find your location value.)

## 1. Enter calibration mode.

Press the [ON/OFF] key to turn the power off. While pressing both the [RE-ZERO] key and the [UNITS] key, press the [ON/OFF] key. Cal will be displayed.

## 2. Select a digit to be changed.

Press the [UNITS] key. 9798 will be displayed. Press the [RE-ZERO] key. The decimal point will move and the last digit will be selected. Select a digit to be changed with the [UNITS] key. The first digit after decimal point is the selected digit.

## 3. Set the value.

Change the value of the selected digit by pressing the [RE-ZERO] key.

## 4. Save the value in memory.

While pressing the [UNITS] key, press the [RE-ZERO] key to save the value. Then end will be displayed.

# SPECIFICATIONS

MODEL	HL-1000WP	HL-300WP	HL-3000WP
Capacity	1000 g	300 g	3000 g
	2.2 lb	10.58 oz	6 lb 9.8 oz
Resolution	0.5 g	0.1 g	1 g
	0.001 lb	0.01 oz	0.1 oz
Non-linearity	±1 g	±0.2 g	±2 g
Repeatability	0.5 g	0.1 g	1 g
Span drift	±0.015% / °C TYP (5°C~35°C / 41°F~95°F)		
Operating temp.	-10°C~40°C / 14°F~104°F, Less than 85%RH		
Display	12 mm / 0.47 inches, 7segment liquid crystal display		
Display update	Approximately 4 times per second		
Power	6 x R6P / LR6 / "AA" size batteries or AC adapter		
Battery life	Approximately 100 hours with manganese type 200 hours with alkaline cells at 20°C / 68°F		
Platform size	128 (W) x 128 (D) mm / 5.04 (W) x 5.04 (D) inches		
Dimensions	169.6 (W) x 219.4 (D) x 63.4 (H) mm 6.68 (W) x 8.64 (D) x 2.50 (H) inches		
Weight (approximately)	870 g / 1.9 lb		
Calibration weight	1000 g ± 0.1 g	300 g ± 0.02 g	3000 g±0.2 g
Accessories	This manual		
Options	AC adapter		

## The Value of Gravity at Various Locations

Amsterdam	9.813 m/s <sup>2</sup>	Manila	9.784 m/s <sup>2</sup>
Athens	9.807 m/s <sup>2</sup>	Melbourne	9.800 m/s <sup>2</sup>
Auckland, NZ	9.799 m/s <sup>2</sup>	Mexico City	9.779 m/s <sup>2</sup>
Bangkok	9.783 m/s <sup>2</sup>	Milan	9.806 m/s <sup>2</sup>
Birmingham	9.813 m/s <sup>2</sup>	New York	9.802 m/s <sup>2</sup>
Brussels	9.811 m/s <sup>2</sup>	Oslo	9.819 m/s <sup>2</sup>
Buenos Aires	9.797 m/s <sup>2</sup>	Ottawa	9.806 m/s <sup>2</sup>
Calcutta	9.788 m/s <sup>2</sup>	Paris	9.809 m/s <sup>2</sup>
Cape Town	9.796 m/s <sup>2</sup>	Rio de Janeiro	9.788 m/s <sup>2</sup>
Chicago	9.803 m/s <sup>2</sup>	Rome	9.803 m/s <sup>2</sup>
Copenhagen	9.815 m/s <sup>2</sup>	San Francisco	9.800 m/s <sup>2</sup>
Cyprus	9.797 m/s <sup>2</sup>	Singapore	9.781 m/s <sup>2</sup>
Djakarta	9.781 m/s <sup>2</sup>	Stockholm	9.818 m/s <sup>2</sup>
Frankfurt	9.810 m/s <sup>2</sup>	Sydney	9.797 m/s <sup>2</sup>
Glasgow	9.816 m/s <sup>2</sup>	Taichung	9.789 m/s <sup>2</sup>
Havana	9.788 m/s <sup>2</sup>	Taiwan	9.788 m/s <sup>2</sup>
Helsinki	9.819 m/s <sup>2</sup>	Taipei	9.790 m/s <sup>2</sup>
Kuwait	9.793 m/s <sup>2</sup>	Tokyo	9.798 m/s <sup>2</sup>
Lisbon	9.801 m/s <sup>2</sup>	Vancouver, BC	9.809 m/s <sup>2</sup>
London (Greenwich)	9.812 m/s <sup>2</sup>	Washington, DC	9.801 m/s <sup>2</sup>
Los Angeles	9.796 m/s <sup>2</sup>	Wellington, NZ	9.803 m/s <sup>2</sup>
Madrid	9.800 m/s <sup>2</sup>	Zurich	9.807 m/s <sup>2</sup>



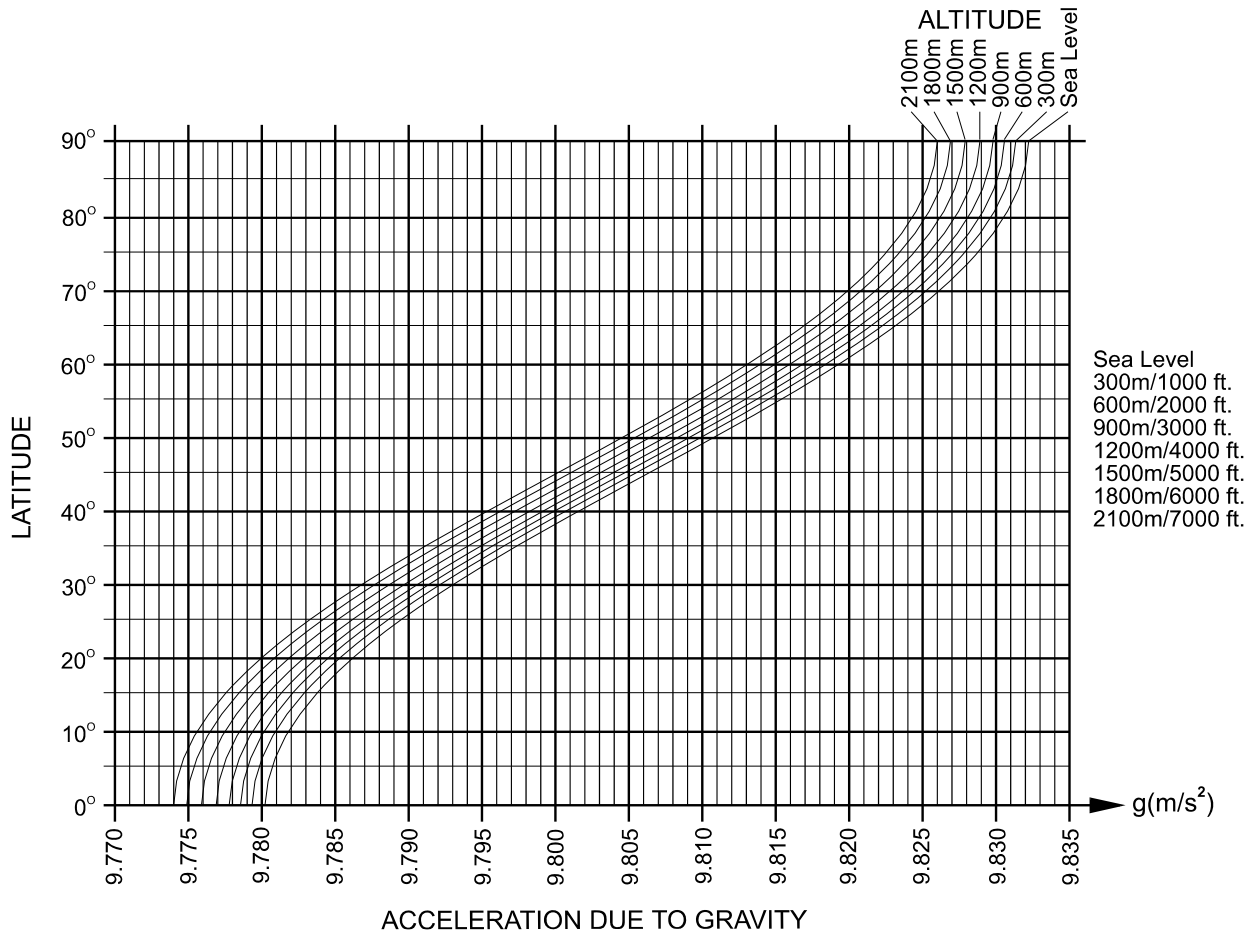

## World Map

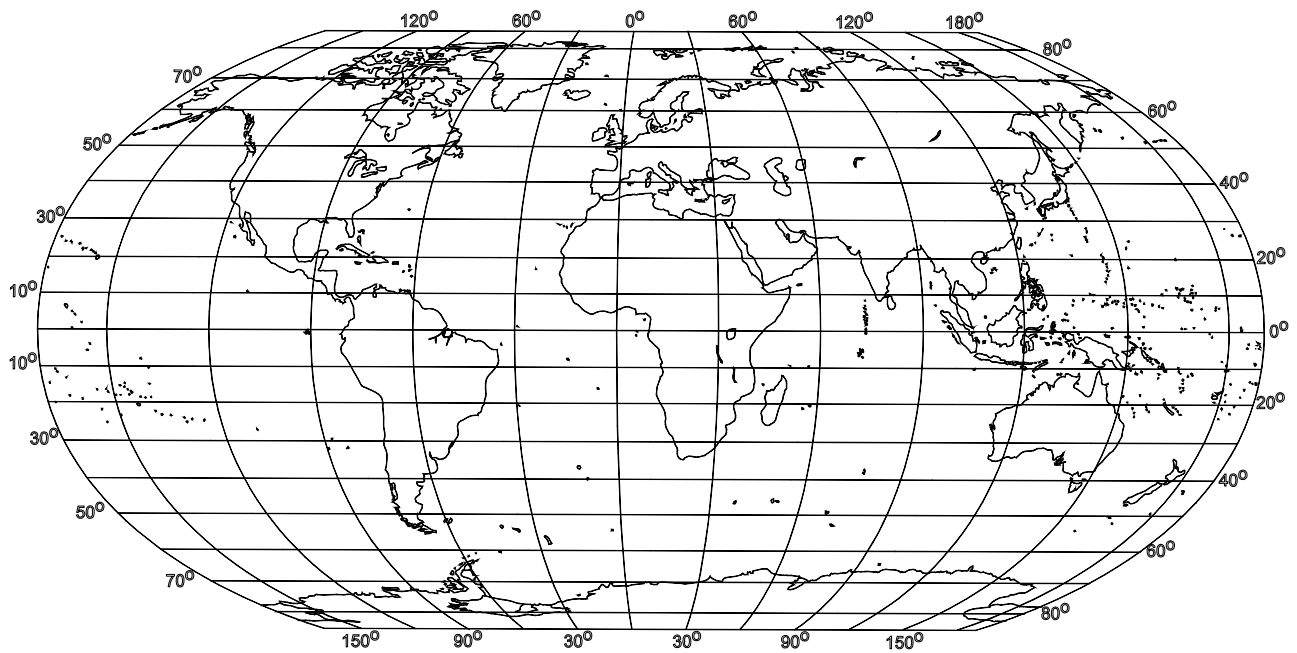



## **A&D Company, Limited**

3-23-14 Higashi-Ikebukuro, Toshima-ku, Tokyo 170-0013 JAPAN  
Telephone: [81] (3) 5391-6132 Fax: [81] (3) 5391-6148

## **A&D ENGINEERING, INC.**

1555 McCandless Drive, Milpitas, CA. 95035 U.S.A.  
Telephone: [1] (408) 263-5333 Fax: [1] (408) 263-0119

## **A&D INSTRUMENTS LTD.**

Unit 24/26 Blacklands Way, Abingdon Business Park, Abingdon, Oxon, OX14 1DY United Kingdom.  
Telephone: [44] (1235) 550420 Fax: [44] (1235) 550485

## **<German Sales Office>**

Große Straße 13 b 22926 Ahrensburg GERMANY  
Telephone: [49] (0) 4012 459230 Fax: [49] (0) 4102 459231

## **A&D MERCURY PTY. LTD.**

32 Dew Street, Thebarton, South Australia 5031 AUSTRALIA  
Telephone: [61] (8) 8352-3033 Fax: [61] (8) 8352-7409

## **A&D KOREA Limited**

8th Floor, Manhattan Bldg. 36-2 Yoido-dong, Youngdeungpo-ku, Seoul, KOREA  
Telephone: [82] (2) 780-4101 Fax: [82] (2) 782-4280