



This document hosted by
OldWillKnottScales
~ ~ CLICK HERE ~ ~
to visit us the next
time you need a scale!

Valor™ 5000

Compact Industrial Portion Scales



SUPPORTS HACCP COMPLIANCE

Speed, Durability and Cleanliness Designed for All-Purpose and Food Service Use

The OHAUS Valor™ 5000 is a rugged, multi-use scale designed for use in a wide variety of preparation and service applications. Ideally suited for food portioning and check weighing, the Valor 5000 Scale combines lightning fast display updates, a smooth easy to clean shape, and high precision load cells. The Valor 5000 is right at home in restaurants, bakeries, food manufacturing and all other areas requiring fast operation, spill resistant design, and flexible cordless battery operation.

Standard Features Include:

- Easy to clean smooth ABS plastic housing with included in-use cover and stainless steel pan construction
- NSF listed/certified, USDA-AMS accepted and supports HACCP compliance
- Easy to see bright backlit 5 digit LCD
- Multiple weighing units including: kg, g, lb, oz (fractional and decimal), lb:oz
- Multiple weighing modes: percent weighing, static weighing, positive/zero/negative static checkweighing
- Three bright LEDs (yellow, green, red) and beeper for indication in checkweigh operation
- Fast stabilization with Auto-Tare
- Remote tare foot switch connection
- Integrated level bubble and adjustable feet
- Standard AC power adapter and internal lead acid rechargeable battery pack with low battery warning

Valor™ 5000 Compact Industrial Portioning

Easy to Set-Up for Your Operation:

The OHAUS Valor 5000 Has All The Features You Need:

- **Selectable Weighing Units** – The Valor 5000 can be set up to display all, some, or only one weighing unit to match the requirements of your operation.
- **Lb & Oz Display** – The Valor 5000 can display a decimal pound to 3 decimal places, as well as fractional or decimal ounces, and can even display results in a combined lb:oz display.
- **Metric Display** – For metric use, the Valor 5000 can display results in kilograms or grams with a readability ranging from 0.5g to 2 g, depending on model.
- **Percent Weight** – Allows users to compare the weight of a sample as a percentage of a reference weight, useful for Baker's Percentages.
- **Change Units Quickly** – The unit displayed can be changed with a single key press.
- **Set It Up and Lock It In** – The Valor 5000 can be set to the mode and weighing units required, and then locked-in using either software or hardware locks. The OHAUS Valor 5000 can be locked to ensure the configuration you choose is the configuration you use!
- **Easy to Calibrate** – The Valor 5000's software menu allows the Valor 5000 to be calibrated to ensure accurate results. To prevent accidental recalibration, the Valor 5000 also can be configured using software and hardware calibration lockouts.

For Checkweighing Applications, The Valor 5000 Can Be Quickly Configured:

The Valor 5000 can be set to either simply display a weight, or can be set to act as a dedicated, low-profile checkweigher for portioning and grading:

- **Portioning and Prepackaging** – With the positive checkweighing mode for packaging, add to the portion on the pan until you reach the weight you need.
- **Portioning Out of the Box** – Use the negative checkweighing mode for portioning and pizza making, portioning out of a container on the pan until the required weight is reached.
- **Sorting & Grading** – The “zero” checkweighing method is designed for sorting and grading operations, so you can check portions against preset limits.
- **Quickly Set Targets** – Target weights can be entered quickly using the dedicated Setpoint key.
- **Bright LED's and Buzzer Speed Use** – Progress against weight targets can be indicated with the three LED's, with indications for Over, Accept and Under with selectable audible buzzer.

Outline Dimensions

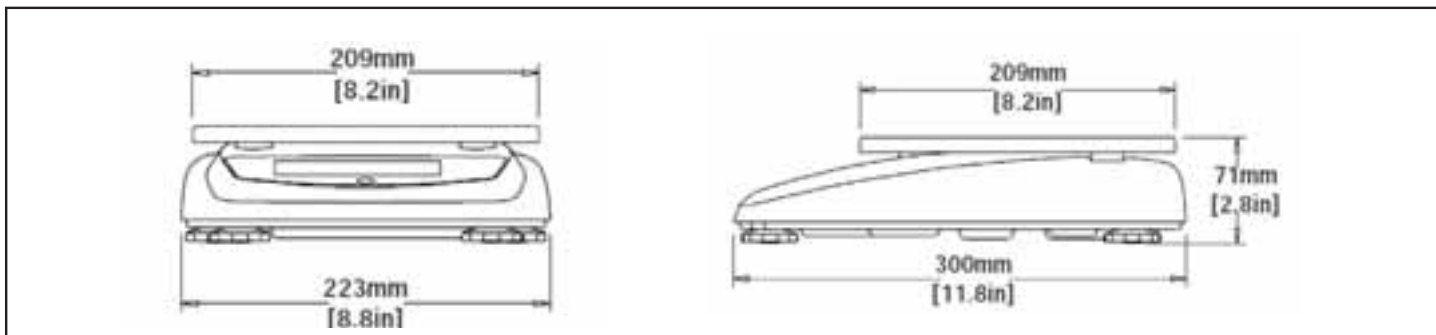

Designed for Food Service Use:

Fast, Easy-To-Read Display – The Valor 5000 is designed to clearly and quickly display weighing results:

- Large, backlit LCD display
- Fast display updates – within 2 seconds
- Bright LED indicators for Checkweighing mode
- Text display of weight units – no cryptic unit designations or hard-to-read annunciators
- Audible buzzer alerts user when limits are reached
- Battery power level indicator
- Bright annunciators for scale stability, center of zero, net and tare weights, checkweighing mode indication



Manual or Auto Tare – The Valor 5000 can be configured to tare three ways:

- Manual taring using the large, dedicated Tare key
- The Valor 5000 can be set-up to automatically tare the first weight placed on the pan
- For hands-free operation, the Valor 5000 can also be tared using the optional foot switch

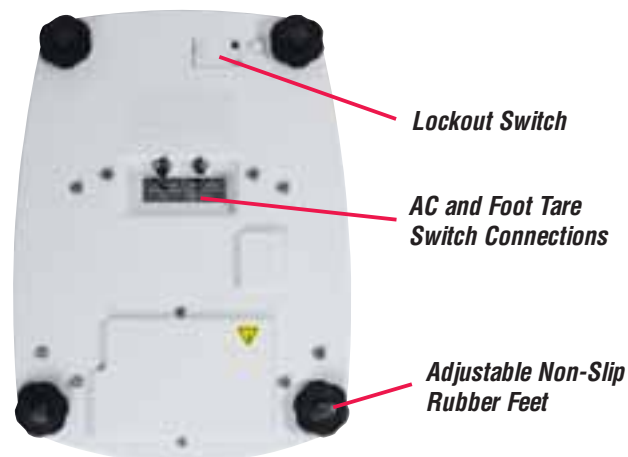

Valor™ 5000 Compact Portion Scales

Specifications

Model	V51PH3	V51PH6	V51PH15	V51PH30
Capacity x Readability (Max x d non-approved)	6 lb x 0.0002 lb	15 lb x 0.001 lb	30 lb x 0.001 lb	60 lb x 0.002 lb
	96 oz x 0.005 oz	240 oz x 0.01 oz	480 oz x 0.02 oz	960 oz x 0.05 oz
	96 oz x 1/4 oz	240 oz x 1/4 oz	480 oz x 1/4 oz	960 oz x 1/4 oz
	6 lb 0 oz x 0.1 oz	15 lb 0 oz x 0.1 oz	30 lb 0 oz x 0.1 oz	60 lb 0 oz x 0.1 oz
	6 lb 0 oz x 1/4 oz	15 lb 0 oz x 1/4oz	30 lb 0 oz x 1/4 oz	60 lb 0 oz x 1/4 oz
	3 kg x 0.0001 kg	6 kg x 0.0002 kg	15 kg x 0.001 kg	30 kg x 0.001 kg
	3000 g x 0.1 g	6000 g x 0.2 g	15000 g x 1 g	30000 g x 1 g
Model	V51P3	V51P6	V51P15	V51P30
Capacity x Readability (Max x d non-approved)	6 lb x 0.001 lb	15 lb x 0.002 lb	30 lb x 0.005 lb	60 lb x 0.01 lb
	96 oz x 0.02 oz	240 oz x 0.05 oz	480 oz x 0.1 oz	960 oz x 0.2 oz
	96 oz x 1/4 oz	240 oz x 1/4 oz	480 oz x 1/4 oz	960 oz x 1/4 oz
	6 lb 0 oz x 0.1 oz	15 lb 0 oz x 0.1 oz	30 lb 0 oz x 0.1 oz	60 lb 0 oz x 0.2 oz
	6 lb 0 oz x 1/4 oz	15 lb 0 oz x 1/4oz	30 lb 0 oz x 1/4 oz	60 lb 0 oz x 1/4 oz
	3 kg x 0.0005 kg	6 kg x 0.001 kg	15 kg x 0.002 kg	30 kg x 0.005 kg
	3000 g x 0.5 g	6000 g x 1 g	15000 g x 2 g	30000 g x 5 g
Weighing Units	Pound, decimal ounce, 3/4, 1/2, and 1/4 fractional ounce, gram, kilogram, combined lb:oz display (either decimal or fractional ounces)			
Application Modes	Weighing, Checkweighing, Percent Weighing			
Display	0.75-in (19mm) high 5-digit, 7-segment backlit blue LCD display			
Display Indicators	Stability, center of zero, tare or net weight, battery status, checkweigh mode			
Checkweighing Indicators	3 LED (yellow, green, red) with configurable operation and alert beeper			
Keyboard	4 – button membrane switch			
Environmental Protection	IP 43			
Tare Range	Full capacity by subtraction			
Stabilization Time	< 2 seconds			
Auto-Zero Tracking	Off, 0.5, 1 or 3 divisions			
Overload Capacity	150% of capacity			
AC Power	9 VDC 0.5A AC wall adapter 100-120 V AC, 50/60 Hz			
Battery	Internal rechargeable sealed lead-acid battery with 120 hours continuous use			
Calibration	User-selectable external span or linearity calibration			
Operating Temperature and Humidity Range	14° to 104°F / -10° to 40°C, 10 to 85% relative humidity, non-condensing			
Pan Size	8.2 x 8.2 in / 209 x 209 mm			
Scale Dimensions WxHxD	9 x 12 x 2.8 in / 300 x 223 x 71 mm			
Shipping Dimensions WxHxD	15.8 x 12.6 x 7.3 in / 400 x 320 x 185 mm			
Net Weight	5.5 lb / 2.5 kg			
Shipping Weight	8.8 lb / 4 kg			

Physical Features

ABS top and bottom housings, dishwasher safe stainless steel pan, clear in-use cover, backlit LCD display, rubber user-adjustable leveling feet, front panel leveling bubble, internal rechargeable lead-acid battery, external AC wall adapter, weight/mode stability/center of zero/net weight/tare weight/text unit indication, 4-bar battery status indicator with low-battery warning, 3 LED's and buzzer for use in checkweighing mode, dedicated tare key, audible buzzer with user-selectable volume control, selectable scale auto-off, sealable scale configuration and calibration lockout switch.

Operational Features

Selectable environmental averaging settings, backlight control with auto-off option, selectable weighing units, configurable checkweighing mode, configurable software lockout menu, span or linearity calibration in kg or lb unit with optional external masses, semi-automatic or automatic tare, selectable auto-zero tracking.

Accessories

Foot switch (p/n 71169633); hard shell carry case (p/n 80251394); flat pan (p/n 80251141); in-use cover (p/n 80251140)

Compliance

- **Food Service:** NSF Listed/Certified to NSF/ANSI 169-2005 *Special Purpose Food Equipment and Devices* (formerly NSF C-2); USDA/AMS Accepted to NSF/3-A 14159-1 *Hygiene Requirements for the Design of Meat and Poultry Processing Equipment*; meets requirements for HACCP conformity.
- **Electrical/Emissions:** UL C US listed, meets AS/NZS4251.1 Emission/AS/NZS4252.1 Immunity, FCC Class B Part 15 operation, Industry Canada Class B.
- **Quality:** OHAUS quality management system registered to ISO 9001:2000

OHAUS CORPORATION

* 19A Chapin Road
P.O. Box 2033
Pine Brook, NJ 07058 USA

Tel: 800.672.7722
973.377.9000
Fax: 973.593.0359

www.ohaus.com

With offices throughout Europe,
Asia, and Latin America

* ISO 9001
Registered Quality Management System

80774361 © Copyright Ohaus Corporation

