



This document hosted by
OldWillKnottScales
~ ~ CLICK HERE ~ ~
to visit us the next
time you need a scale!

Ranger™ Series

Compact Industrial Bench Scales



(Non-SW models)

Precise, Fast Industrial Bench Scales in Rugged Cast Aluminum Housings

The OHAUS Ranger™ line of compact bench scales has been upgraded and expanded with new software and models for even better performance in demanding industrial applications. The Ranger line now has an enhanced microprocessor and updated filtering software for improved performance in the lab, on the production line, or in the field.

Every Ranger features a large, backlit LCD display with fast display of weighing results within 2 seconds, as well as a RS232 port for quick connectivity to printers and systems. For use in applications requiring additional filtering, the Ranger series now includes dynamic weighing software allowing weigh determination where vibration is an issue.

For applications where water resistance is required, the Ranger series now offers NEMA4/IP65 models with washable aluminum housings, with the same software and features as the non-washdown versions of the Ranger series.

Every Ranger is designed with OHAUS' easy-to-use software interface, making operation intuitive with a consistent feel across all four Ranger lines: Ranger, Ranger High Resolution, Ranger Count and Ranger Count Plus. No matter the industrial need, there is a Ranger for that application!

Standard Features Include:

- High performance strain gage loadcells, encased in a tough painted cast aluminum housing
- Wide range of platforms and capacities from 6lb to 120lb
- Weigh in lb, oz, kg, g or metric tonne units
- Large, backlit LCD display
- Dynamic weighing software included
- 1:30,000 default resolution
- NTEP 1:6,000 legal for trade resolution (non-washdown versions only)
- RS232 interface included, optional second RS232 available
- Built-in AC with hardwired plug, factory-installed NiMH battery optional
- NEMA 4/IP65 washdown (SW) models available

Ranger™ Series Compact Bench Scales

Specifications

Model	RD3RS	RD6RS	RD12LS	RD30LS	RD60LS
Default Capacity x Readability	6.6138 x 0.0002 lb 105.822 x 0.002 oz 3 x 0.0001 kg 3000 x 0.1 g 0.003 x 0.000001 t	13.2275 x 0.0005 lb 211.640 x 0.005 oz 6 x 0.0002 kg 6,000 x 0.2 g 0.006 x 0.000001 t	26.456 x 0.001 lb 423.30 x 0.02 oz 12 x 0.0005 kg 12,000 x 0.5 g 0.012 x 0.000001 t	66.138 x 0.002 lb 1,058.20 x 0.02 oz 30 x 0.001 kg 30,000 x 1 g 0.03 x 0.000001 t	132.275 x 0.005 lb 2116.50 x 0.05 oz 60 x 0.002 kg 60,000 x 2 g 0.06 x 0.000002 t
NTEP Certified Capacity x Readability	6 x 0.001 lb 3 x 0.0005 kg 3,000.0 x 0.5 g	12 x 0.002 lb 6 x 0.001 kg 6,000 x 1 g	24 x 0.005 lb 12 x 0.002 kg 12,000 x 2 g	60 x 0.01 lb 30 x 0.005 kg 30,000 x 5 g	120 x 0.02 lb 60 x 0.01kg 60,000 x 10g
Scale with NiMH Internal Battery	RD3RS/1	RD6RS/1	RD12LS/1	RD30LS/1	RD60LS/1
Scale with Second RS232	RD3RS/2	RD6RS/2	RD12LS/2	RD30LS/2	RD60LS/2
Scale with NiMH Battery and 2nd RS232	RD3RS/3	RD6RS/3	RD12LS/3	RD30LS/3	RD60LS/3

Ranger IP65 Washdown Compact Bench Scales

Model	RD3RSW	RD6RSW	RD12LSW	RD30LSW	RD60LSW
Default Capacity x Readability	6.6138 x 0.0002 lb 105.822 x 0.002 oz 3 x 0.0001 kg 3000 x 0.1 g 0.003 x 0.000001 t	13.2275 x 0.0005 lb 211.640 x 0.005 oz 6 x 0.0002 kg 6,000 x 0.2 g 0.006 x 0.000001 t	26.456 x 0.001 lb 423.30 x 0.02 oz 12 x 0.0005 kg 12,000 x 0.5 g 0.012 x 0.000001 t	66.138 x 0.002 lb 1,058.20 x 0.02 oz 30 x 0.001 kg 30,000 x 1 g 0.03 x 0.000001 t	132.275 x 0.005 lb 2116.50 x 0.05 oz 60 x 0.002 kg 60,000 x 2 g 0.06 x 0.000002 t
NTEP Certified Capacity x Readability	6 x 0.001 lb 3 x 0.0005 kg 3,000.0 x 0.5 g	12 x 0.002 lb 6 x 0.001 kg 6,000 x 1 g	24 x 0.005 lb 12 x 0.002 kg 12,000 x 2 g	60 x 0.01 lb 30 x 0.005 kg 30,000 x 5 g	120 x 0.02 lb 60 x 0.01kg 60,000 x 10g
Scale with NiMH Internal Battery	RD3RSW/1	RD6RSW/1	RD12LSW/1	RD30LSW/1	RD60LSW/1

General Specifications

Platform Size (w x d)	9.5 x 8 in / 24 x 20 cm	14 x 9.5 in / 35 x 24 cm
Safe Overload Capacity	150% of capacity	
Construction	Stainless steel weighing pan / Painted cast-aluminum housing	
Protection	IP43 for non-SW units, NEMA 4/IP65 for SW units	
Weighing Units / Modes	lb, oz, g, kg / Weighing, Dynamic Weighing	
Display	0.63 inch / 16 mm digit height (backlit LCD)	
Keyboard	Six button membrane switch	
Stabilization Time	< 2 seconds	
Auto Zero Tracking	0.5, 1, 2, 5, 10d, OFF	
Power	Internal AC adapter, rechargeable NiMH battery optional	
Calibration	External span, 20 - 100%	
Operating Temperature	14° F to 104° F / - 10° C to 40° C	
Net (Shipping) Weight	12 lb / 5.1 kg (15 lb / 6.6 kg)	20 lb / 8.9 kg (25 lb / 11.1 kg)
Scale Dimensions (W x D x H)	10.5 x 13.2 x 4 in / 26.5 x 33.5 x 10 cm	14.2 x 14.6 x 4.5 in / 36 x 37 x 11.5 cm
Shipping Dimensions (W x D x H)	16.5 x 19 x 10 in / 42 x 48 x 25 cm	20 x 20.5 x 10.5 in / 52 x 53 x 27 cm

Standard Features

RS232 bi-directional interface, backlit LCD display, auto-off timer, internal AC power supply, leveling feet, leveling bubble, loop for security device, 6-key membrane keypad, rugged cast aluminum housing, auto zero tracking, retain zero data during power off, user selectable graduation, user selectable averaging and level sensitivity, display units user selectable, automatic taring, configurable primary and secondary RS232 port settings with programmable output header, supervisor lockout capability.

Factory Options and Accessories

Internal NiMH rechargeable battery, 2nd RS232 port, protective in-use cover, carrying case, anti-theft device, RS232 cables.

Compliance

- **Electrical/Emissions:** CE listed, meets AS/NZS4251.1 Emission/AS/NZS4252.1 Immunity, FCC Class B Part 15 operation, Industry Canada Class A. cULus AC power pack. Compliant to Directive 2002/96/EC on waste electrical and electronic equipment (WEEE).
- **Legal-for-Trade:** Non-SW RD models listed above are NTEP Certified (certificate #07-026, Class III), OIML R76 Class III and EC Type Approved
- **Quality:** Ohaus quality management system registered to ISO 9001:2000

Outline Dimensions

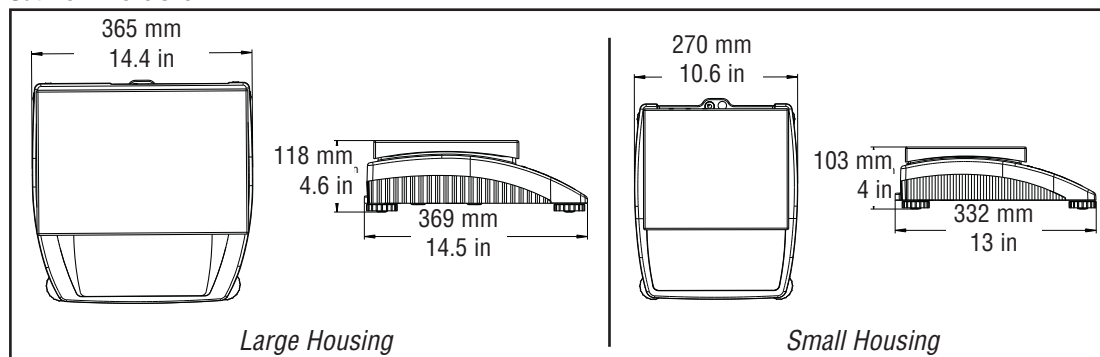

OHAUS CORPORATION

* 19A Chapin Road
P.O. Box 2033
Pine Brook, NJ 07058 USA

Tel: 800.672.7722
973.377.9000

Fax: 973.593.0359

www.ohaus.com

With offices throughout Europe,
Asia, and Latin America

* ISO 9001

Registered Quality Management System

