



This document hosted by
OldWillKnottScales
~ ~ CLICK HERE ~ ~
to visit us the next
time you need a scale!

Defender™ 7000XW

Advanced Xtreme Square Washdown Scales



Advanced Smart Functionality, Durability, OHAUS Quality and Value

The OHAUS Defender™ 7000 Series is a feature-rich line of bench scales, combining a stainless steel D71XW indicator with a square, all-stainless steel washdown base and a stainless steel column. Ideal for shipping and receiving, production, packaging and general commercial and industrial weighing applications, the Defender 7000 offers a multifunctional indicator with multiple weighing units, alpha-numeric keypad and software modes to meet the requirements of industrial and lab applications. With rugged construction, comprehensive yet intuitive software and multiple connectivity options, the Defender 7000 can meet the needs of demanding industrial operations.

Standard Features Include:

- All stainless-steel construction with IP66/NEMA4X protection for indicator, with loadcells protected to IP67
- 10,000-12,500d default resolution
- Quick display of results using large dual line LCD with high-contrast white backlight
- Temporary display of 10x readability in weighing mode using quick key press
- Easy to operate with positive feedback 5-function key and alpha-numeric membrane keypad
- Weighs in one or more units: kg, g, lb, oz, lb:oz (decimal), tonnes and user-definable custom unit
- Multiple weighing modes including Counting, Percent Weighing, Dynamic/Animal Weighing, Checkweighing, Display Hold, and Accumulation.
- 255 item Library function
- Internal power supply with universal line cord – optional NiMH internal rechargeable power pack available
- Includes RS232 interface with GMP/GLP data output including date and time, and external analog base input
- Base and indicator connected using quick connect plug
- Optional interfaces include DC relay control kit, AC relay control kit, 2nd RS232 and RS485/422

Defender™ 7000XW Advanced Xtrem

The Defender 7000 Offers Multiple Features and Easy Configuration:

To meet different operational needs, the Defender 7000 includes a suite of configurable software:

- Counting mode for packaging and inventory control, enabling counting into a container or out of a container for bulk operations. Supports a maximum counting resolution to 1:500,000 (minimum APW equal to 0.1d), selectable auto-optimization of average piece weight (APW). APW data can be displayed at any time using a quick key press.
- Percent Weighing mode for formulation and mixing applications, with display of reference weight with quick key press.
- Dynamic/Animal Weighing with selectable averaging times from 0-60 seconds.
- Checkweighing function for count and weight checking, with display of results using LCD display and red/yellow/green LEDs. Audible beeper can be configured to prompt when weight is within range, under, over, or under or over range. Target values can be displayed at any time using a quick key press.
- Display Hold mode for weighing large packages, holds last stable weight on display until cleared manually or automatically
- The Defender 7000 weighs in one or more user-selectable units: kg, g, lb, oz, lb:oz (decimal), tonnes and user-definable custom unit
- Supports GMP/GLP data output with date, time user ID, project ID and scale ID. The Defender 7000 features selectable print options for data and print format
- To limit operator access to functions, the Defender 7000 offers both software lockouts for menu items as well as individual key functions.
- Library storage for up to 255 memory records that may contain data from a combination of different modes. These reference data can be quickly and conveniently recalled for use with the active mode.
- Multi-language feature allows the user to display operation and menu text in the language of their choice: English, Spanish, French, German, Italian. This allows for convenience and ease of training and operation of the Defender 7000.
- Accumulation mode with statistics feature allows totalizing weight and count values manually or automatically. The total accumulated value is displayed in real-time. With the press of the "Info" key, the number of weighments, average, standard deviation, minimum, maximum and difference are displayed. These statistical values can also be printed.
- Dual scale connections are built-in for 2-scale counting configuration. Connect two bases, a higher resolution base to optimize average piece weight, in conjunction with a large capacity base to weigh/count in bulk.

Outline Dimensions

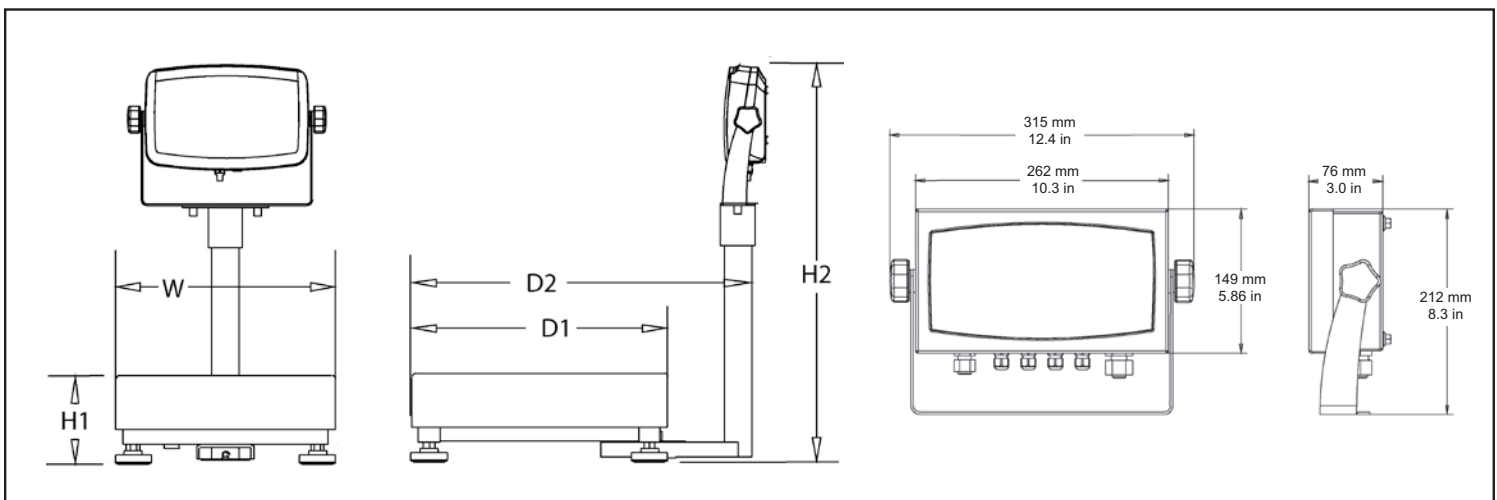

the Square Washdown Scales

Standard Features:

Optional NiMH Battery

Allows for use in environments where an electrical outlet may not be readily available

Internal Slot for Capacity Label

Protects label from the effects of moisture and external environments

Stainless Steel 304 NEMA 4X/IP66 Enclosure

Indoor/outdoor protection against falling dirt, rain, sleet, snow, windblown dust, splashing and corrosion

3-Color LED Checkweigh Indication

with configurable beeper alert

High-Visibility Dual Line LCD Display

with bright white LED backlight and fast display stable weight within 2 seconds

Included Table/Wall Mount Bracket

With large ergonomic adjustable knobs to maximize viewing angles.

One-Key, Multiple Mode Selection

Counting, Dynamic Weighing, Display Hold, Percent Weighing and Checkweighing

Hinged Front Cover

Only four sealing screws secure the housing for ease of servicing, while still ensuring IP66 seal integrity



Stay Connected

Built in RS232 bi-directional interface and external tare input, optional RS485/422, optional second RS232 and optional AC or DC relay

Universal Switching Power Supply

Automatically adapts to different voltages and frequencies; plug anywhere, anytime

Stainless Steel Columns

Available in both short and tall lengths

Durable Base Frame Construction

Stainless steel pans and form-and-weld frames (R, L bases) provide maximum durability, rigidity and structural integrity. Load-unload cycle tested to ensure long-term performance.



Fully Adjustable Feet

Four rugged, adjustable feet help prevent slippage on wet or uneven surfaces

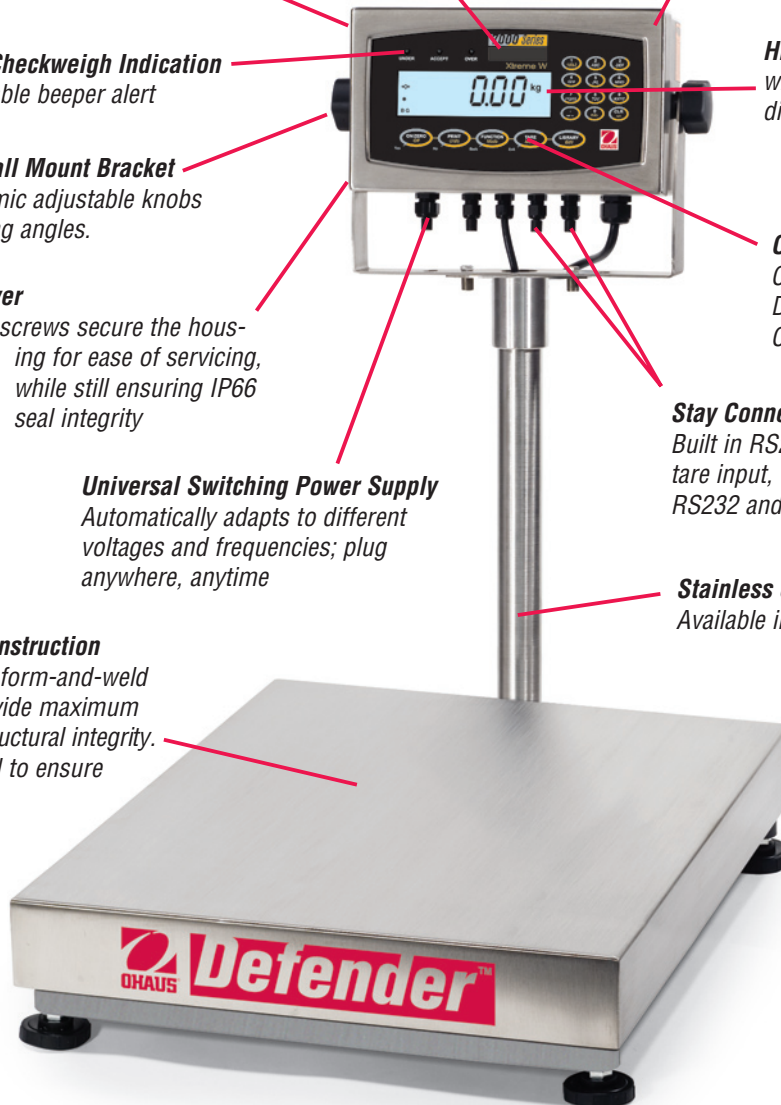

Options and Accessories

Interface Options

	OHAUS Number
AC Relay Kit.....	80500720
DC Relay Kit.....	80500727
RS485/422 Interface Kit.....	80500731
Second RS232 Interface Kit.....	80500733
Foot Switch.....	71173378

Power Options

Rechargeable Battery Kit, T71P/T71XW.....	80500729
---	----------

Other Accessories

	OHAUS Number
Compact Dot Matrix Impact Printer.....	80252042
Compact Dot Matrix Impact Printer.....	80252042
Compact Thermal Printer.....	80251992
OHAUS Collect Software.....	80500746
TAL Software WinWedge.....	SW12W
Paper for Printer, 80252042 (1 roll).....	80251932
Ribbon for Printer, 80252042.....	80251933
RS232 Cable & Adapter, 80252042 Printer to T71XW.....	80252574
RS232 Cable, PC 9 Pin to T71XW.....	80500552
RS232 Cable, PC 25-pin to T71XW.....	80500553

Defender™ 7000XW Xtreme Scales

Specifications

Model	D71XW10WR3	D71XW25WR3	D71XW50WL4	D71XW100WL4	D71XW250WX4
Capacity (max) x Default Readability (d)	25lb x 0.002lb 400oz x 0.05oz 25lb : 0.05oz 10kg x 0.001kg 10000g x 1g	50lb x 0.005lb 800oz x 0.1oz 50lb x 0.1oz 25kg x 0.002kg 25000g x 2g	100lb x 0.01lb 1600oz x 0.2oz 100lb : 0.2oz 50kg x 0.005kg 50000g x 5g	250lb x 0.02lb 4000oz x .5oz 250lb : .5oz 100kg x 0.01kg 100000g x 10g	500lb x 0.05lb 8000oz x 1oz 500lb : 1oz 250kg x 0.02kg 250000g x 20g
Maximum Displayed Resolution	1:12500	1:12500	1:10000	1:12500	1:12500
Indicator Model	T71XW				
Column	13.8 in / 350 mm stainless steel		26.8 in / 680 mm stainless steel		
Construction	Stainless steel indicator, removable weighing platform, column, base construction and loadcell				
Safe Overload Capacity	150% of maximum capacity				
Protection	NEMA 4X/IP66 for indicator, IP67 for loadcell				
Weighing Units	lb, oz, lb:oz, kg, g, custom unit				
Modes/Features	Static Weighing (single or dual range), Dynamic Weighing, Counting, Checkweighing, Percent Weighing, Display Hold, Accumulation, Library				
Display	6-digit, 7-segment LCD, 25mm/1 inch high primary digits, dual line, with high-contrast white LED backlight				
Keypad	Positive feedback membrane keys, 5 function keys and alpha-numeric keypad				
Stabilization Time	Within 2 seconds				
Auto-zero Tracking	Off, 0.5, 1 or 3 d				
Zeroing Range	2% or 100% of capacity				
Calibration	Span: 1kg or 1lb to 100% of capacity / Linearity: 3 or 5 point				
Power	100-240 VAC / 50-60Hz internal universal power supply / 6 'C' cell batteries (not supplied) with 80 hour life				
Interface	RS232 and external tare input				
Operating Temperature Range	14°F to 104°F / -10°C to 40°C				
Shipping Dimensions (L x W x H)	19.3 x 16.1 x 17.3 in 490 x 410 x 440 mm		31.2 x 23.6 x 9.5 in 810 x 600 x 240 mm		39.4 x 29.9 x 9.8 in 1000 x 760 x 250 mm
Scale Dimensions (W x H1 x H2 x D1 x D2)	12 x 3.7 x 23.2 x 12 x 16.7 in 305 x 95 x 590 x 305 x 425 mm		18 x 4.5 x 37 x 18 x 22.7 in 457 x 115 x 940 x 457 x 577 mm		24x5.4x37x24x28.7 in 610 x 137 x 940 x 610 x 730 mm
Net Weight	35.5 lb / 16.1 kg		69.6 lb / 31.6 kg		86.8 lb / 39.4 kg
Shipping Weight	40.8 lb / 18.5 kg		74.5 lb / 33.8 kg		100.9 lb / 45.8 kg

Features

T71XW: Stainless steel water resistant NEMA 4X / IP66 housing, integral faceplate supports for easy servicing, backlit LCD weight display, checkweighing indication (green, yellow, red), membrane keypad with raised tactile keys, built-in bi-directional RS232 with manual/continuous/interval printing, external tare input, hardware configuration lockout switch, internal switching power supply with hardwired cord.

Other Features

Zero point calibration, calibration test, span or linear calibration, selectable auto-zero tracking range, selectable stability range, selectable averaging level, selectable LCD backlight, selectable auto shutoff, retain zero weight data after power-off, Geo gravity adjustment, selectable key beep, key function lock, menu lock, selectable power-on and calibration unit, battery status display, display of gross/net weight, indication of stability, center of zero, over- and underweight, overload and underload conditions. Configuration menus for PRINT1, PRINT2, COM1, COM2, and I/O.

Compliance

- **Safety and EMC:** ^cUL_{us} 2005/95/EC low voltage directive: EN60950-1:2001, FCC Part 15 Class A 2004/108/EC Compliant to Directive 2002/96/EC on waste electrical and electronic equipment (WEEE)
- **Quality:** OHAUS quality management system registered to ISO 9001:2000

OHAUS CORPORATION

* 19A Chapin Road
P.O. Box 2033
Pine Brook, NJ 07058 USA

Tel: 800.672.7722
973.377.9000

Fax: 973.593.0359

www.ohaus.com

With offices throughout Europe,
Asia, and Latin America

* ISO 9001

Registered Quality Management System

80774477 © Copyright Ohaus Corporation

