



This document hosted by
OldWillKnottScales
~ ~ CLICK HERE ~ ~
to visit us the next
time you need a scale!

Defender™ 5000XW

Xtreme Square Washdown Scales



Smart Functionality, Durability, OHAUS Quality and Value

The OHAUS Defender™ 5000 Series is a feature-rich line of bench scales, combining a stainless steel D51XW indicator with a square, all-stainless steel washdown base and a stainless steel column. Ideal for production, packaging and general commercial and industrial weighing applications where full washdown protection is required, the Defender 5000 offers a multifunctional indicator with multiple weighing units and software modes to meet the requirements of industrial and lab applications. With rugged steel construction, comprehensive yet intuitive software and multiple connectivity options, the Defender 5000 can meet the needs of demanding industrial operations.

Standard Features Include:

- All stainless-steel construction with IP66/NEMA4X protection for indicator, with loadcells protected to IP67
- 10,000-12,500d default resolution
- Quick display of results using large LCD with high-contrast white backlight
- Temporary display of 10x readability in weighing mode with quick key press
- Easy to operate with 4-key membrane keypad with raised tactile keys
- Weighs in one or more units: kg, g, lb, oz, lb:oz (decimal), tonnes and user-definable custom unit
- Multiple weighing modes including Counting, Percent Weighing, Dynamic/Animal Weighing, Checkweighing, and Display Hold.
- Internal universal switching power supply with hardwired line cord – optional NiMH internal rechargeable power pack available
- Includes RS232 interface with GMP/GLP data output including date and time
- Optional interfaces include DC relay control kit, AC relay control kit, 2nd RS232 and RS422/485

Defender™ 5000XW Xtreme Square W

The Defender 5000 Offers Multiple Features and Easy Configuration:

To meet different operational needs, the Defender 5000 includes a suite of configurable software:

- Counting mode for packaging and inventory control, enabling counting into a container or out of a container for bulk operations. Supports a maximum counting resolution to 1:300,000 (minimum APW equal to 0.1d), selectable auto-optimization of average piece weight (APW). APW data can be displayed at any time using a quick key press.
- Percent Weighing mode for formulation and mixing applications, with display of reference weight with quick key press.
- Dynamic/Animal Weighing with selectable weigh times from 0-60 seconds
- Checkweighing function for packaging and weight checking, with display of results using LCD display and red/yellow/green LEDs. Audible beeper can be configured to prompt when weight is within range, under, over, or under or over range. Target weight values can be displayed at any time using a quick key press.
- Display Hold mode for weighing large packages holds last stable weight on display until cleared
- The Defender 5000 weighs in one or more user-selectable units: kg, g, lb, oz, lb:oz (decimal), tonnes and user-definable custom unit
- It supports GMP/GLP data output with date, time user ID, project ID and scale ID. The Defender 5000 features selectable print options for data and print format
- To limit operator access to functions, the Defender 5000 offers both software lockouts for menu items as well as individual key functions.

Outline Dimensions

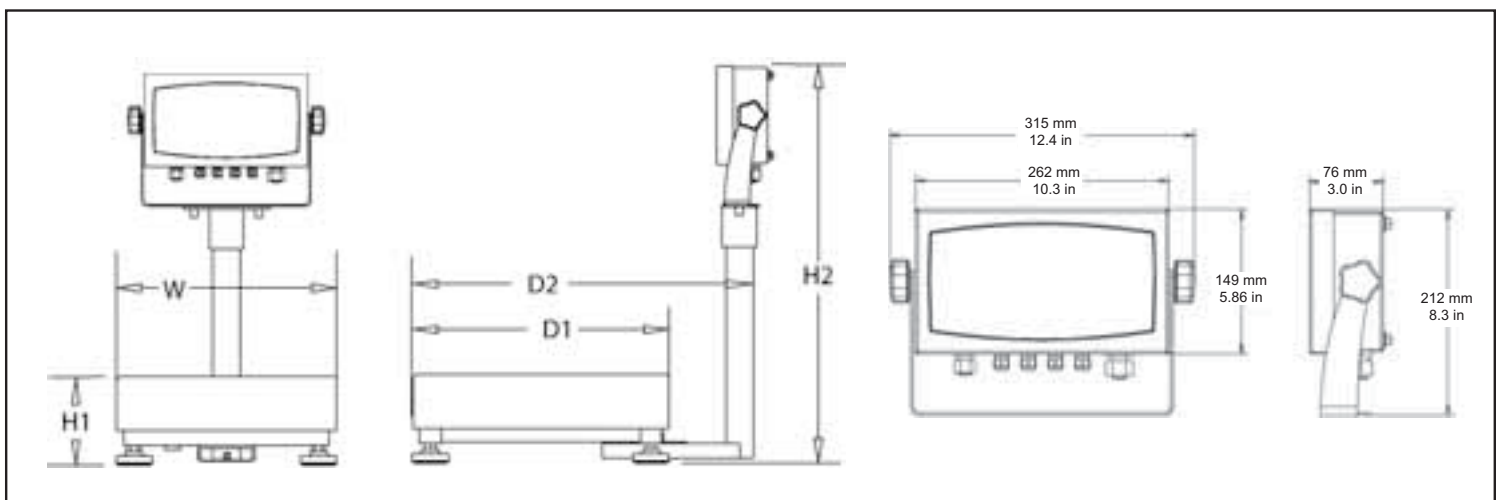

Washdown Scales

Standard Features:

Optional NiMH Battery
Allows for use in environments where an electrical outlet may not be readily available

Internal Slot for Capacity Label
Protects label from the effects of moisture and external environments

Stainless Steel 304 NEMA 4X/IP66 Enclosure
Indoor/outdoor protection against falling dirt, rain, sleet, snow, windblown dust, splashing and corrosion

3-Color LED Checkweigh Indication
with configurable beeper alert

High-Visibility LCD Display
with bright white LED backlight and fast display stable weight within 2 seconds

Included Table/Wall Mount Bracket
With large ergonomic adjustable knobs to maximize viewing angles.

One-Key, Multiple Mode Selection
Counting, Dynamic Weighing, Display Hold, Percent Weighing and Checkweighing

Hinged Front Cover
Only four sealing screws secure the housing for ease of servicing, while still ensuring IP66 seal integrity

Stay Connected
Built in RS232 bi-directional interface and external tare input, optional RS485/422, optional second RS232 and optional AC or DC relay

Universal Switching Power Supply
Automatically adapts to different voltages and frequencies; plug anywhere, anytime

Stainless Steel Columns
Available in both short and tall lengths

Durable Base Frame Construction
Stainless steel pans and form-and-weld frames (R, L bases) provide maximum durability, rigidity and structural integrity. Load-unload cycle tested to ensure long-term performance.

Fully Adjustable Feet
Four rugged, adjustable feet help prevent slippage on wet or uneven surfaces

Options and Accessories

Interface Options

| | OHAUS Number |
|---------------------------------|--------------|
| AC Relay Kit..... | 80500720 |
| DC Relay Kit..... | 80500727 |
| RS485/422 Interface Kit | 80500731 |
| Second RS232 Interface Kit..... | 80500733 |
| Foot Switch | 71173378 |

Power Options

| | |
|---|----------|
| Rechargeable Battery Kit, T51P/T51XW..... | 80500729 |
|---|----------|

Other Accessories

| | |
|---|----------|
| RS232 Cable to SF42 Printer..... | 80500574 |
| RS232 Cable to PC 25-pin..... | 80500553 |
| RS232 Cable to PC 9-pin..... | 80500552 |
| Compact Impact Printer, 42 Column | SF42 |
| Paper for SF42 printer (5 pack)..... | 12101511 |
| Ribbon for SF42 printer..... | 12101512 |

Defender™ 5000XW Xtreme Scales

Specifications

| Model | D51XW10WR3 | D51XW25WR3 | D51XW50WL4 | D51XW100WL4 | D51XW250WX4 |
|---|---|--|--|--|--|
| Capacity (max) x Default Readability (d) | 25lb x 0.002lb 400oz x 0.05oz 25lb : 0.05oz 10kg x 0.001kg 10000g x 1g | 50lb x 0.005lb 800oz x 0.1oz 50lb x 0.1oz 25kg x 0.002kg 25000g x 2g | 100lb x 0.01lb 1600oz x 0.2oz 160lb : 0.2oz 50kg x 0.005kg 50000g x 5g | 250lb x 0.02lb 4000oz x .5oz 250lb : .5oz 100kg x 0.01kg 100000g x 10g | 500lb x 0.05lb 8000oz x 1oz 500lb : 1oz 250kg x 0.02kg 250000g x 20g |
| Maximum Displayed Resolution | 1:12500 | 1:12500 | 1:10000 | 1:12500 | 1:12500 |
| Indicator Model | T51XW | | | | |
| Column | 13.8 in / 350 mm stainless steel | | 26.8 in / 680 mm stainless steel | | |
| Construction | Stainless steel indicator, removable weighing platform, column, base construction and loadcell | | | | |
| Safe Overload Capacity | 150% of maximum capacity | | | | |
| Protection | NEMA 4X/IP66 for indicator, IP67 for loadcell | | | | |
| Weighing Units | lb, oz, lb:oz, kg, g, custom unit | | | | |
| Modes | Static Weighing, Dynamic Weighing, Counting, Checkweighing, Percent Weighing, Display Hold | | | | |
| Display | 1 in / 25mm high 6-digit, 7-segment bright white backlit LCD | | | | |
| Keyboard | 4-button membrane switch | | | | |
| Stabilization Time | Within 2 seconds | | | | |
| Auto-zero Tracking | Off, 0.5, 1 or 3 d | | | | |
| Zeroing Range | 2% or 100% of capacity | | | | |
| Calibration | Span: 1kg or 1lb to 100% of capacity / 3-point linearity (0-50% – 100% fixed) | | | | |
| Power | 100-240 VAC / 50-60Hz internal universal power supply / 6 'C' cell batteries (not supplied) with 80 hour life | | | | |
| Interface | RS232 and external tare input | | | | |
| Operating Temperature Range | 14°F to 104°F / -10°C to 40°C | | | | |
| Shipping Dimensions (L x W x H) | 19.3 x 16.1 x 17.3 in 490 x 410 x 440 mm | | 31.2 x 23.6 x 9.5 in 810 x 600 x 240 mm | | 39.4 x 29.9 x 9.8 in 1000 x 760 x 250 mm |
| Scale Dimensions (W x H1 x H2 x D1 x D2) | 12 x 3.7 x 23.2 x 12 x 16.7 in 305 x 95 x 590 x 305 x 425 mm | | 18 x 4.5 x 37 x 18 x 22.7 in 457 x 115 x 940 x 457 x 577 mm | | 24x5.4x37x24x28.7 in 610 x 137 x 940 x 610 x 730 mm |
| Net Weight | 35.5 lb / 16.1 kg | | 69.6 lb / 31.6 kg | | 86.8 lb / 39.4 kg |
| Shipping Weight | 40.8 lb / 18.5 kg | | 74.5 lb / 33.8 kg | | 100.9 lb / 45.8 kg |

Features

T51XW: Stainless steel water resistant NEMA 4X / IP66 housing, integral faceplate supports for easy servicing, backlit LCD weight display, checkweighing indication (green, yellow, red), membrane keypad with raised tactile keys, built-in bi-directional RS232 with manual/continuous/interval printing, external tare input, hardware configuration lockout switch, internal switching power supply with hardwired cord.

Other Features

Zero point calibration, calibration test, span or linear calibration, selectable auto-zero tracking range, selectable stability range, selectable averaging level, selectable LCD backlight, selectable auto shutoff, retain zero weight data after power-off, Geo gravity adjustment, selectable key beep, key function lock, menu lock, selectable power-on and calibration unit, battery status display, display of gross/net weight, indication of stability, center of zero, over- and underweight, overload and underload conditions. Configuration menus for PRINT1, PRINT2, COM1, COM2, and I/O.

Compliance

- **Safety and EMC:** cUL_{US} 2005/95/EC low voltage directive: EN60950-1:2001, FCC Part 15 Class A 2004/108/EC Compliant to Directive 2002/96/EC on waste electrical and electronic equipment (WEEE)
- **Quality:** OHAUS quality management system registered to ISO 9001:2000

OHAUS CORPORATION

* 19A Chapin Road
P.O. Box 2033
Pine Brook, NJ 07058 USA

Tel: 800.672.7722
973.377.9000
Fax: 973.593.0359

www.ohaus.com

With offices throughout Europe,
Asia, and Latin America

* ISO 9001

Registered Quality Management System

80774415 © Copyright Ohaus Corporation

