

## Table of Contents

Introduction.....	1
Section One.....	3
Installing Your Scale.....	3
SETUP.....	3
EXPERIMENTATION.....	5
Section Two.....	6
Understanding Your Scale.....	6
KEYBOARD FUNCTIONS.....	6
DISPLAY SYMBOLS.....	6
MESSAGES.....	6
LED.....	7
Section Three.....	8
Using Your Scale.....	8
BASIC WEIGHING.....	8
CONVERTING THE WEIGHING UNITS.....	8
WEIGHING WITH A CONTAINER.....	8
BASIC COUNTING USING THE SAMPLE SIZE KEY.....	9
USING THE MINIMUM SAMPLE SIZE AND MINIMUM ACCURACY FEATURE.....	10
COUNTING WITH ACCURACY ENHANCEMENT.....	10
REVERSE COUNTING OR KITTING.....	12
PRINTING OUT INFORMATION.....	13
INTERFACING WITH A COMPUTER.....	13
Appendix I.....	14
Set-Up Functions.....	14
Appendix II.....	15
Calibration.....	15
Appendix III.....	16
Glossary of Terms.....	16
Appendix IV.....	17
RS-232 Serial Data Communications.....	17
The RS-232 Interface Hardware.....	17
Appendix V.....	19
Accessories and Options.....	19
Appendix VI.....	20
In Case of Difficulty.....	20
Appendix VII.....	22
Battery Option.....	22
INSTALLATION.....	22
BATTERY USE FOR PORTABLE SCALE OPERATION.....	23
BATTERY CHARGING.....	23
Appendix VIII.....	24
Specifications.....	24
Appendix IX.....	26
Limited Two-Year Scale Warranty.....	26
Index.....	27



## Introduction

Thank you for purchasing a Setra Quick Count scale. Its ease of operation and durable construction should provide years of convenient and reliable service. While your scale is easy to operate, it is advisable to read this manual carefully before use. It is designed to help you perform weighing, counting, and related operations quickly and accurately.

This manual is divided into four sections. Section One, "Installing Your Scale," explains the proper installation of your scale. Section Two, "Understanding Your Scale," explains the various keys, operations and messages you will encounter while using your scale. Section Three, "Using Your Scale," provides the detailed instructions necessary to perform your scale's various operations. The Appendices include examples, a glossary of terms, and set-up information for advanced operations.

For advanced programming of the Quick Count using an Auto Count™ 200 or PC, get a copy of the *Setra Quick Count Technician's Guide* by contacting your local authorized Setra dealer or call Setra toll free at 1-800-25-SETRA.

Typographical Conventions used in this manual include the following:

1. **Bold lower case characters** indicate specific keys on the scale keyboard.
2. "Quotation marks" enclose messages you receive from the scale display.
3. nnn indicates a number will appear in the display message.

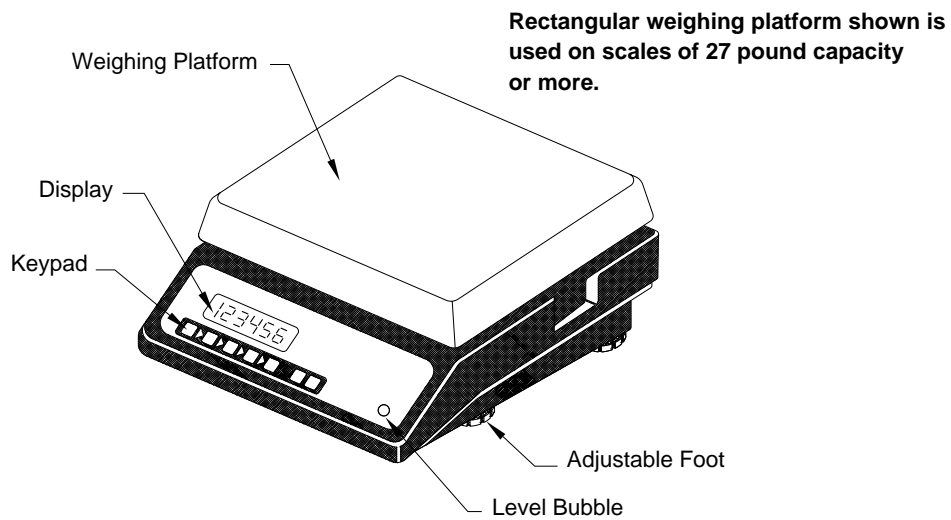
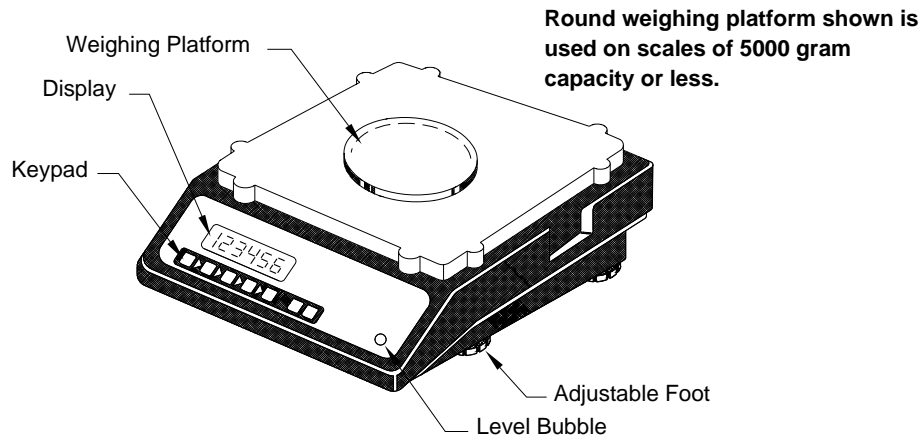
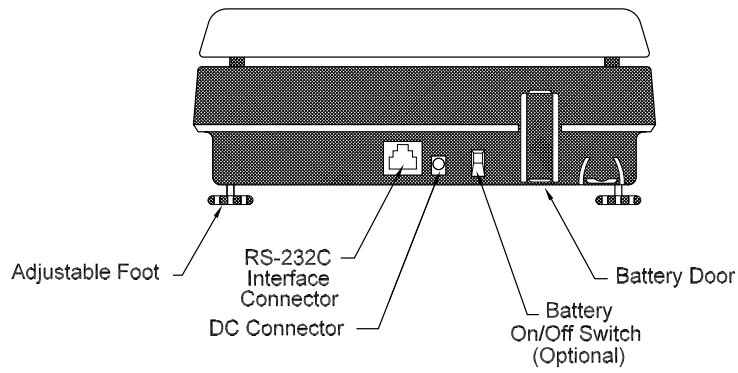

FIGURE 1. Components and features of the Setra Quick Count.

# Installing Your Scale

## SETUP

### 1. Locating your scale

The rugged design of your Setra Quick Count scale ensures that it will operate well in typical factory or office environments. Nonetheless, you should treat your scale as you would any piece of precision equipment, locating it on a clean, dry surface; protected, where possible, from extremes of draft and vibration.

### 2. Leveling your scale

- a. Retract the right rear foot completely into the scale.
- b. Adjust the two front feet until the leveling bubble is centered in the circle.
- c. Extend the right rear foot until it contacts the mounting surface. Make certain that all four feet are contacting the mounting surface.
- d. Make certain the scale is stable by placing both hands on the scale platform and attempt to rock the scale. If it moves, adjust the leveling feet until the scale stands firmly on the mounting surface.

### 3. Installing the weighing pan

Using the Allen wrench provided, secure the pan support to the four posts over the sensor. Next, place the weighing pan over the pan support.

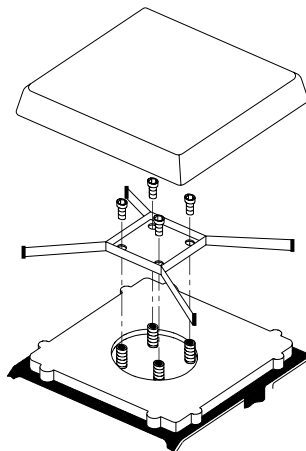

An Allen wrench and four socket head cap screws are provided to assist in the installation of the load frame support for scales using a rectangular weighing platform.

### 4. Connecting your scale to an AC outlet

To connect your scale to an AC outlet, insert the appropriate end of the AC adaptor into an electrical outlet. Now connect the other end into the back of the scale (see FIGURE 1). Once you have plugged your scale into a live outlet, it is automatically on, unless the scale is equipped with a battery, in which case the on-off switch on the rear panel should be put in the 'on' position to

power up the scale. The scale draws very little current from an outlet and may be left connected. This keeps your scale ready to use with no "warm-up" time.

## EXPERIMENTATION

### 1. Display test

When your scale is first powered on, it automatically runs through a display test; lasting about six seconds. The scale next displays " C nnn g" where nnn equals the full scale capacity in grams), performs self-diagnostics to ensure proper operation and then sets itself to zero. A wake up message is always transmitted upon power up. (If a printer is connected to the scale, the scale model, capacity and software version will be printed. If the scale is connected to a computer the wake up message may be disregarded.) The scale is then ready for use. For best accuracy, allow the scale to warm up for 5 minutes.

### 2. Using your scale for the first time

It is important that you read this operator's manual thoroughly to ensure proper use of your scale. Nonetheless, experimenting with your scale and its keyboard prior to reading this manual in its entirety will not harm your scale (provided it is not overloaded), and may actually give you a better understanding of the instructions in this manual. If you instruct the scale to do something it is not capable of doing, the scale will respond by displaying the message " UnABLE" . To continue experimenting, simply press the **clear** key.

## Understanding Your Scale

### KEYBOARD FUNCTIONS

- zero** Assigns the pan and whatever is currently being weighed a value of zero. While the scale is determining a stable zero reading, the display will indicate " bUSY" .
- sample size** Displays preprogrammed sample sizes (10, 25, 50 or 100 pieces).
- count** Instructs the scale to begin or resume counting. This key may also be used to " update" the average piece weight for increased counting accuracy.
- print** Scale sends any displayed and stored information to a printer, computer (or other RS-232 peripheral device).
- units** Converts the weighing units of measure (e.g. changes from grams to ounces).
- clear** Clears the last number entered or operation requested, and displays weight.

### DISPLAY SYMBOLS

- OK Reading shown is stable. Further operations may be performed.
- PC Reading shown is given in number of pieces.
- g Reading shown is given in grams.
- oz Reading shown is given in ounces.
- lb Reading shown is given in pounds.
- t oz Reading shown is given in troy ounces.
- dwt Reading shown is given in pennyweights.
- c Reading shown is given in carats.

### MESSAGES

- C nnn g Displayed when the scale is powered on. " nnn" equals the scale's full capacity in grams.
- bUSY The scale is waiting for a stable reading.
- UnAbLE The scale is unable to complete your requested operation. Press the **clear** key and select another operation.
- FLASHING



DISPLAY	The weight on the pan exceeds the capacity of the scale; the pan is not properly seated or the scale is under loaded.
OFLO	The displayed count exceeds six digits (999,999).
UPdAtE	The scale is recalculating the average piece weight to enhance counting accuracy.
Add nnn.PC	The scale is requesting an additional number of pieces (nnn) to satisfy any minimum accuracy setup requirements.
Sub nnn.PC	When kitting, the scale is requesting an additional number of pieces (nnn) be removed to satisfy any minimum accuracy setup requirements.
rEF n.n	The scale is displaying the current software version number (n.n).

## LED

low bat	If lit, battery needs to be recharged. (Battery option only)
---------	--

## Section Three

# Using Your Scale

### BASIC WEIGHING

To weigh a sample on your scale, use the following procedure:

1. Press the **zero** key.
2. Place the object(s) to be weighed on the pan.
3. Wait for the "OK" symbol, then read the weight from the display.

### CONVERTING THE WEIGHING UNITS

Your Quick Count scale is capable of weighing in any of the units listed in the DISPLAY SYMBOLS portion of this guide. To convert from one unit to another, simply press the **units** key. Each time you press the key the display is converted to the next unit in line. Continue pressing the key until the units you wish to use are displayed. The order of units is as follows: GRAMS - OUNCES - POUNDS - TROY OUNCES - PENNYWEIGHTS - CARATS - GRAMS.

It is possible to limit which units of measure are displayed when the **units** key is repeatedly pressed. The units of measure can be limited to two, three, four, etc. or it can be entirely disabled so that only one unit of measure can be used. Contact your local Authorized Setra dealer for more information, or refer to the *Setra Quick Count Technician's Guide*.

### WEIGHING WITH A CONTAINER

You can use your scale to weigh objects (or liquids) by placing or pouring them into a container. To weigh objects or liquids in this manner, WITHOUT including the weight of the container, use the following procedure:

1. Press the **zero** key. Place the empty container on the pan.
2. Press the **zero** key again.
3. Wait for the "OK" symbol. Place or pour objects or liquids into the container.
4. Wait for the "OK" symbol, then read the net weight from the display.

## BASIC COUNTING USING THE SAMPLE SIZE KEY

To count a number of like objects on the scale, use the following procedure:

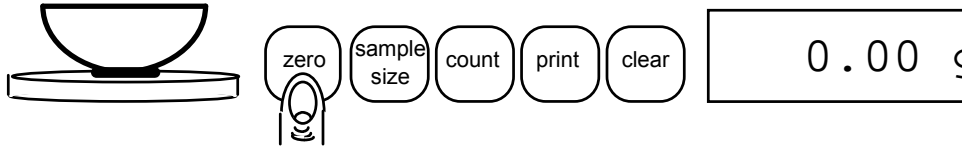

1. Place an empty container on the scale. Press the **zero** key.

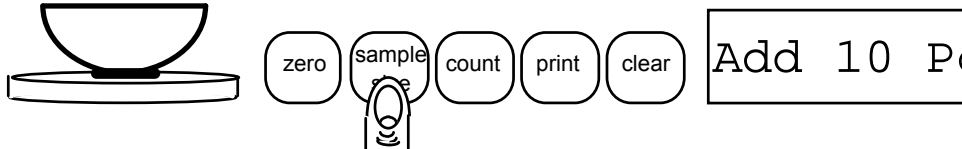

2. Press the **sample size** key. Each time the key is pressed the requested sample size will increase (i.e., Add 10, 25, 50, 100 PCs).

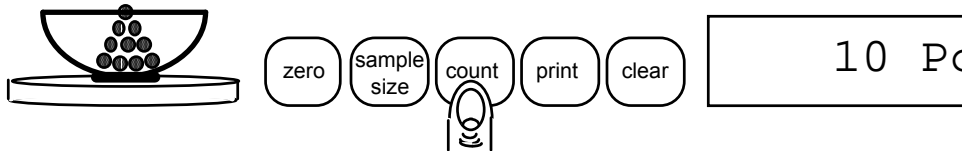

3. Place the requested number of pieces in the container. Press the **count** key.

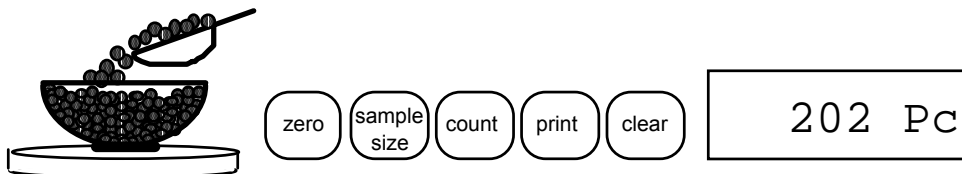

4. Fill the container to the desired number of pieces.

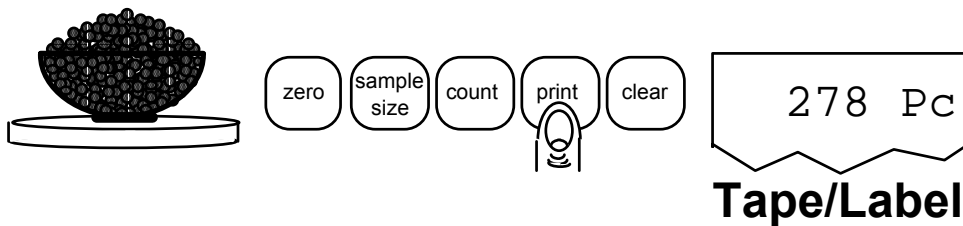

5. Press the **print** key to generate a tape/label or to transmit the data from the RS-232 port.

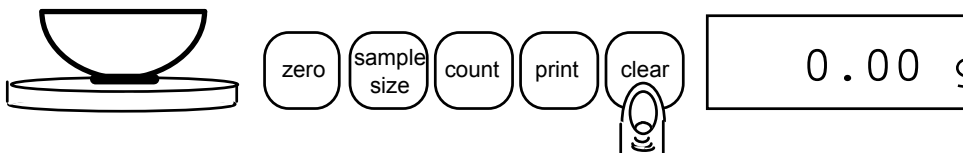

6. Remove the pieces from the container and press the **clear** key to return the scale to the weight display.

## USING THE MINIMUM SAMPLE SIZE AND MINIMUM ACCURACY FEATURE

Counting errors can be caused by non-uniformity in the parts being counted or by insufficient sample weight. To reduce these errors your scale has been designed with two special features. The minimum sample size feature ensures that the scale will calculate an average piece weight from a large enough sample which is nearly equal to the average piece weight of the entire lot. This feature prevents an operator from using a sample size which is too small and could be "biased", i.e., not truly representative of the distribution of unequal parts in the lot to be counted. Setting the scale to require a larger minimum sample will reduce the error which is introduced by non-uniformity.

The minimum accuracy feature ensures that the total sample weight is heavy enough to keep counting errors very small. The higher the degree of accuracy desired, the larger the total sample weight that will be required. This means that even if the sample satisfies the minimum sample size requirement it may still be too light to achieve the accuracy level selected and therefore the scale will request more pieces.

Your scale has been preprogrammed at the factory with a minimum sample requirement of 10 pieces and a minimum accuracy requirement of 95%. If you wish to change these settings contact your local authorized Setra dealer or refer to the *Setra Quick Count Technician's Guide*.

## COUNTING WITH ACCURACY ENHANCEMENT

When counting parts that are not uniform in weight, you can periodically update the average piece weight (APW) and thereby increase the accuracy. Each time the **count** key is pressed, the scale will update the APW as long as the additional weight is less than or equal to the previous sample weight. If the added weight is more than 100% of the previous sample, the APW will not be updated. For example, if you start with a sample size of 10 pieces then add 10 more and press the **count** key, the APW will be recalculated based on a 20 piece sample. The next time you wanted to update the APW you could add up to 20 pieces. If you added 11 or more to the original 10 piece sample, the APW would not be updated and would continue to represent the original 10 pieces. To count using this accuracy enhancement feature, follow the procedure below.

1. Place an empty container on the scale and press the **zero** key.
2. Press the **sample size** key. The scale display will say " Add 10. PC" .  
  
(The sample size requirement can be increased by pressing the **sample size** key repeatedly. The predetermined sample sizes are: 10, 25, 50 and 100 pcs. A custom sample size may be preset using the minimum sample size setup feature. If preset, the scale will never request a sample size less than the preset minimum sample size.)
3. When you reach the desired sample size, place the requested number of pieces in the container.
4. Press the **count** key. Wait for the " OK" symbol then slowly add pieces until the displayed count is increased by 100% or less.
5. Press the **count** key. The scale displays " UPdAtE" and automatically calculates a new average piece weight based on the larger number of pieces. If " UPdAtE" is not displayed, the additional pieces have exceeded 100% of the previous sample weight and the APW will not be updated.

NOTE: The accuracy enhancement feature is disabled if the average piece weight has been scanned in from a bar code or entered via a computer.

## REVERSE COUNTING OR KITTING

Using this feature, you can place a container full of pieces on your scale and count the number of pieces removed. This is especially helpful when kitting (counting out a certain number of pieces to be packed together). To perform reverse counting or kitting, use the following procedure:

1. Place a container full of pieces you wish to count on the pan.
2. Press the **zero** key.
3. Press the **sample size** key.
4. The scale display will say " Add 10. PC" .  
  
(The sample size requirement can be increased by pressing the **sample size** key repeatedly. The predetermined sample sizes are: 10, 25, 50 and 100 pcs. This sequence of predetermined sample sizes will repeat itself as the **sample size** key is pressed. A custom sample size may be preset by using the minimum sample size setup feature. If this is the case, the scale will never request a sample size less than the preset minimum sample size.)
5. When you reach the desired sample size, REMOVE the requested number of pieces from the container.
6. Press the **count** key. If the sample size is not large enough to satisfy the minimum accuracy requirement the display will read " Sub nnn" . Remove the specified number of pieces (i.e., nnn) from the container and press the **count** key again.
7. Remove pieces until the display reads the number of pieces you wish to count out or kit.
8. Press the **zero** key.
9. Repeat Steps 7 and 8 as many times as needed.

## PRINTING OUT INFORMATION

Your Setra Quick Count scale is designed to print out requested or stored information regarding a given batch when connected to an optional serial printer (see Appendix I). To print out information using the Setra Model 240P or 340P dot matrix printer, use the following procedure:

1. Connect the printer's AC adaptor to a 110-volt outlet.
2. Connect the other end of the adaptor to the printer.
3. Connect the appropriate end of the printer connection cord to the printer.
4. Connect the other end of the connection cord to the scale's RS-232 port.
5. Perform the necessary counting or weighing procedures on the scale.
6. Make sure the printer is turned on (as indicated by the printer's green light). If the printer is not on, press the black button on the side of the printer.
7. Press the **print** key on the scale.
8. Repeat Steps 5 through 7 any time you wish to print out information.

- NOTE: a. When using a printer other than the Setra 240P or 340P, set the baud rate and parity of your scale to match the printer (see Appendix I).
- b. It is possible to customize the information to be printed to either a dot matrix printer or thermal printer for bar codes with ScriptCoder™. Contact your local authorized Setra dealer for more information.

## INTERFACING WITH A COMPUTER

Your Setra Quick Count scale is designed to interface with a wide variety of computers. For information on how to connect your scale to a computer and transmit data ask your local authorized Setra dealer for the *Setra Quick Count Technician's Guide*, or request a copy from the factory.

## Set-Up Functions

Your Setra Quick Count scale was programmed at the factory to operate in a prescribed manner. Many of the factory settings can be altered by an authorized Setra dealer to optimize scale performance for your counting or weighing operation. For example, the scale is factory preset to request a minimum of 10 pieces to initiate the counting process. Your dealer can alter the minimum to a smaller or larger sample, such as 5 or 25 pieces. Your dealer can also alter the minimum counting accuracy, the baud rate used for data communications, display hysteresis and print formatting.

Factory settings can also be changed by a scale operator using a Setra Auto Count™ 200, or by using a computer connected to the scale through the bi-directional RS-232 serial data port. For information on how to use a PC to alter factory settings ask your dealer for the *Setra Quick Count Technician's Guide*, or request a copy from the factory.

The following scale settings are available in addition to the factory default settings. Your dealer may change these settings to fit your particular application and so the factory defaults *may not apply*.

Minimum Sample Size(pieces): 0-999 Default: 10,  
25, 50 or 100

Minimum Counting Accuracy: 95-99.99%, none Default: 95%

Baud Rate: 300, 600, 1200, 2400, 4800, 9600 Default:  
2400

Parity: even/odd/none no  
parity

Display Hysteresis: on or off Default: on

Display hysteresis when enabled provides a more stable, easier to read number. Display hysteresis can be set to prevent the last digit from changing if weight changes are less than 1 displayed increment.

Printer Settings: Default: Weight/Count, Average Piece  
Weight, English Format,  
240P 340P

Print Device Type: 240P  
340P with 6 line feeds for 1" length labels  
Auto Count 200 - English/Bar Code  
ScriptCoder - custom English/Bar Code designs

To print a copy of the scale's current setup information use the following procedure. Connect the scale to a printer via the RS-232 serial port. Power up the scale and then *hold the print key down* while the scale completes the countdown and displays the scale capacity, i.e., -2-, -1-, C nnnng. The scale will display "rEF n.n", the software version while printing the current setup information. Press the **clear** key twice to return to the normal weighing mode.



# Calibration

Your Setra Quick Count scale is highly stable, and requires infrequent calibration. While it may be span calibrated as often as desired, the factory calibration is adequate for most counting applications. For precise weighing applications more periodic calibrations may be desirable. To perform a span calibration on Quick Count scales with operating program version 1.3 or higher, use the following procedure:

1. Remove all objects from the pan.
2. Make certain the scale is level.
3. Press the **units** key to place the scale in either the GRAMS or POUNDS weighing mode. (If either of these units of measure are disabled, refer to "Units Enable/Disable Selection" in the *Setra Quick Count Technician's Guide*.)
4. Press the **zero** key and while the scale is displaying "BUSY" \*, press the **units** key.  
The scale will flash "CAL" and return to displaying "BUSY" .
5. The scale will then display "L xxxxx" , where xxxxx is the scale's first calibration point. Press the **sample size** key repeatedly, the scale will display each calibration point available.

To ensure maximum accuracy the calibration point selected should be as close as possible to the scale's full capacity.

6. When the desired calibration point is displayed, load the displayed weight on the pan, and press the **units** key.
7. The scale will display "BUSY" , and then return to the normal weighing mode.
8. Remove the weights from the pan, press **zero** to zero the display.

\* If you are having difficulty entering the calibration mode, gently touch the edge of the weighing pan to prolong the "BUSY" display message in step 4.

## Glossary of Terms

### ACCURACY

The degree of conformity of a measured value to the true value.

### AVERAGE PIECE WEIGHT

The average weight in a sample of like pieces.

### BAUD RATE

The rate at which your scale transmits or receives information to or from a computer or peripheral device.

### DISPLAY HYSTERESIS

The tendency of a scale with a fluctuating reading to stabilize on the higher value.

### KITTING

Repeatedly removing a given number of pieces for inclusion in a kit; e.g., removing the number of like transistors necessary to manufacture a radio.

### PARITY

A bit used to check the validity of the data word.

### PRECISION

The degree of reproducibility which can be placed on an average value derived from multiple measurements usually expressed as one standard deviation (or one sigma).

### REPRODUCIBILITY

See PRECISION.

# RS-232 Serial Data Communications

Your Setra Quick Count comes equipped with a bidirectional RS-232 interface using a default baud rate of 2400 and no parity. Users who have purchased a Setra 240P or 340P printer may simply follow the directions under "Printing Out Information" to connect it to the scale. Users who are interfacing a scale to the Auto Count 200 or to another printer for a custom label design using ScriptCoder should follow the installation instructions in the operator's guides for those products.

### The RS-232 Interface Hardware

Although Setra scales can communicate with almost any RS-232 device, the built-in interface does not include the complete protocol; only the transmit and receive lines of the standard interface are used.

The data format is:

- 1 start bit
- 8 data bits including parity
- 1 stop bit
- 10 bits per frame (framing errors ignored)

NOTE: The scale will transmit using the parity selected; however it does not check the parity it receives.

Use an RS-232 cable to connect the external device to the scale, or construct one following these instructions. The serial port uses an eight pin modular connector. The pinout is as follows:

- 1 ground
- 2 transmit out
- 3 receive in
- 4 no connection
- 5 no connection
- 6 +5V @ 250 mA\* (optional)
- 7 ground
- 8 ground

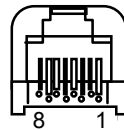

**Modular Jack  
Connector**  
(in back of scale)

\* If the fuse (Setra p/n 404722) is installed, power is provided for the Auto Count 200 bar code option or an intelligent bar code wand (p/n 403676), CCD or laser scanner on pin 6.

NOTE: The "handshake" signals, such as "Clear To Send" (CTS), are not implemented. This requires that the peripheral have a minimal buffer (15 characters).

In addition, some computers which require handshaking will need a connection between two pins on the computer's connector named DTR and DSR (Data Terminal Ready and Data Set Ready) in order to communicate with the scale. CTS (Clear to Send) may also need to be jumpered to RTS (Request to Send) at your computer interface.

The maximum recommended cable length is 15 meters. The cable may be longer if it has less than 2,500 pF capacitance. The load impedance of the device connected should be between 3,000 and 7,000 ohms with not more than 2,500 pF shunt capacitance.

For further information, obtain a copy of the *Setra Quick Count Technician's Guide* by contacting your local authorized Setra dealer.

## Accessories and Options

The following accessories are available for the Setra Quick Count. Ask your dealer for current price information and/or a demonstration.

Part Number	Description
401150	240P PRINTER - 40 column dot matrix tape printer comes pre-interfaced to Setra scales and balances. Printer has an RS-232 serial asynchronous interface with 1.5 kilobyte data buffer and user selectable baud rate. Printing is bidirectional at 2 lines per second, and baud rate is selectable. Dimensions: 8" x 8" x 4" (200 x 200 x 100 mm).
401151	340P LABEL PRINTER - same as the 240P above, but includes sprocket mechanism for label advance. Designed for standard 3-1/2" x 15/16" adhesive backed labels. (Avery #4145 or equivalent.)
404530	BATTERY CONNECTOR ASSEMBLY - designed for portability, this option permits battery operation of the Quick Count scale. Included is an "on-off" switch, external battery charger and a DC. power clip. A battery is <u>not</u> included.
404719	EXTERNAL BATTERY CHARGER - used to charge camcorder style lead-acid battery.
404620	BATTERY - this camcorder style lead-acid battery will provide up to twenty-four hours of scale operation on a full charge. (See Battery Use For Portable Scale Operation, Appendix VII.) Battery is 12 VDC, 2.3 ampere-hours. Use of this battery is limited to scales equipped with the BATTERY CONNECTOR ASSEMBLY (Setra part number 404530.)
404150	AUTO COUNT 200 - scale bar code option allows use of the Setra scale for reading and printing bar code labels.
404910	SCRIPTCODER LABEL DESIGN & CABLE KIT - this programming option allows customization of labels to include any alphanumeric information, scale data fields or ASCII control characters to print any label format including bar codes on thermal printers.

# In Case of Difficulty

Setra Quick Count scales are designed to be easy to use. If, however, you have reached a state in which the scale will no longer follow your instructions, you may wish to "reset" the scale. It is possible to do so by following this sequence.

1. Remove all weights from the pan.
2. Press the **clear** key.
3. Press the **zero** key.

If this procedure does not solve the problem, try briefly unplugging the unit from its power source then plug the unit in again.

To print a copy of the scale's current setup information use the following procedure. Connect the scale to a printer or computer via the RS-232 serial port. Power up the scale and then hold the **print** key down while the scale completes the countdown and displays the scale capacity, i.e., -2-, -1-, C xxxxg. The scale will display "rEF n.n", the software version while printing the current setup information. Press the **clear** key twice to return to the normal weighing mode.

If the scale does not return to normal operation, you may want to completely reset the scale's battery backed memory. This will cause all of the user setups to return to the factory defaults and WILL ERASE ANY SPAN CALIBRATION that may have been performed. To reset the scale's battery backed memory use the following procedure:

1. Remove power from the scale via the scale's power switch (if equipped with one) or by unplugging the AC adaptor.
2. Hold down the **sample size** and **print** keys simultaneously.
3. While holding these two keys down, restore power to the scale. This puts the scale in the diagnostic mode.
4. The scale will display "d-noS". Press the **clear** key. The scale will now perform tests to verify its operation and reset all of the setups to the factory defaults. The scale will then display "PASS".
5. Press the **clear** key. The scale will now perform the normal segment test, capacity and count down displays.

If the unit displays any unusual messages during the warm-up period, or does not return to normal operation, contact an Authorized Setra Service Center or Setra Systems, Inc., as service may be required.

If the scale displays the "bUSY" message for an extended period of time, or the displayed reading is unstable, too much vibration or draft may be present. Relocate the scale away from the source of vibration or shield the scale from draft in order to correct this condition. If vibration or draft is not the cause of the instability, service may be required.

If the scale displays "d-noS", it may have been subjected to an extreme discharge of static electricity or power line fluctuations. The scale can be easily restored to operation by following the procedures outlined in steps #4 and #5 above. Note, the user setups will be restored to the original factory defaults.

If the RS-232 interface does not function correctly, first make certain that you are using the correct RS-232 cable, and that it is securely fastened to both the scale and the peripheral device. If data transmission or reception is still not possible, be certain that both the scale and peripheral device serial ports are set up correctly (baud rate, parity, handshaking, etc.). See Appendix IV.

When communicating with certain types of devices, especially computers, it may be necessary to "cross" the receive and transmit lines of the interface. That is, the receive line of the scale must connect to the transmit line of the external device. Likewise, the transmit line of the scale must connect to the receive line of the external device. Special cables can be purchased for this purpose from a computer dealer.

If the problem still persists, contact your local authorized Setra dealer, refer to the *Setra Quick Count Technician's Guide* or consult Appendix IX, "Limited Two-Year Scale Warranty," for more information.

To obtain a copy of the *Setra Quick Count Technician's Guide* contact your local authorized Setra dealer.

# Battery Option

### INSTALLATION

Disassembly of the entire scale is not required when installing the battery option kit.

1. Position the back of the scale so it overhangs the rear of a work bench (see Figure 2).
2. Remove the (2) Phillips head screws (marked "A" in Figure 2) and the rear panel.
3. Next remove the (2) hex head screws and washers marked "D" in Figure 2.
4. Disconnect the ribbon cable and remove the power circuit board.
5. Install the battery option circuit board and reconnect the ribbon cable. Make sure to loop the battery clip out through the battery door opening.
6. Replace the (2) hex head screws and washers marked "D" in Figure 2.
7. Before replacing the rear panel, remove the pre-cut knockout for the power switch with a hammer and screwdriver. Mount the rear panel onto the scale with the (2) Phillips head screws (marked "A" in Figure 2).
8. Slide the battery halfway into the scale, attach the battery clip, then insert the battery completely into the scale.
9. Slide the battery door closed and the scale is now powered for portable operation.

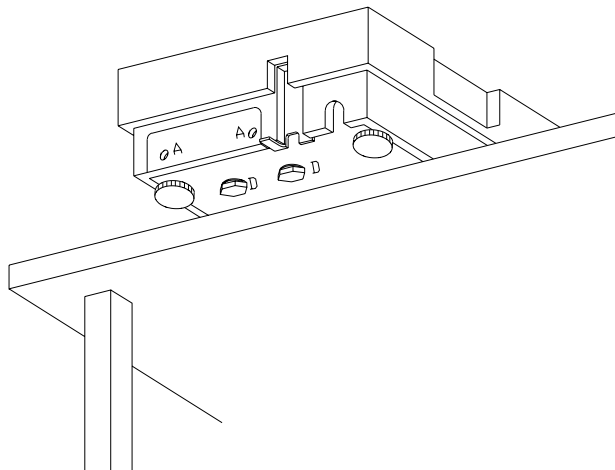

Figure 2. Installing the Battery Option.



## **BATTERY USE FOR PORTABLE SCALE OPERATION**

A fully charged battery will allow a Setra scale to operate for approximately 24 hours before recharging is needed. The battery will last one-half as long or about 12 hours if the scale is equipped with an Auto Count 200. The " low bat" indicating light on the front panel of the scale will light up approximately one hour before recharging is necessary. When battery power is too low for proper scale operation the circuit will automatically shut off the battery and the scale will cease operation.

Replacement and spare batteries can be ordered from Setra Systems (part number 404620).

## **BATTERY CHARGING**

When the " low bat" indicator light on the front panel of the scale turns on, use the following procedure to recharge the battery:

1. Plug the AC adaptor, (Setra part number 404712) into an electrical outlet, and plug the power cable into the scale. Do not remove the battery. The scale will automatically recharge the battery from the electrical outlet regardless if the scale is on or off.
2. The " low bat" indicator light will remain on during recharging until the battery reaches 40% of its rated capacity. This will take between 2 to 2.5 hours depending if the scale is on or off. A battery powering a scale alone will reach 95% of its rated capacity in 8 hours if the power switch is in the " ON" position and in 7 hours if the switch is " OFF" . Note that the indicator light will not light up if the scale switch is " OFF" .
3. If the scale is equipped to power an Auto Count 200 from the scale's battery, it is recommended that battery recharging be done with the scale power switch in the " OFF" position.

Battery charging time may vary slightly depending upon the temperature in the scale operating environment. For applications requiring continuous scale operation it is recommended that the battery be removed from the scale and recharged using the external battery charger (Setra part number 404719).

## Appendix VIII

# Specifications

### Setra Quick Count

CAPACITY	REPRODUCIBILITY	READABILITY	NON-LINEARITY
2.2 lb	+/-0.00002 lb	0.00002 lb	+/-0.00002 lb
5.5 lb	+/-0.00005 lb	0.00005 lb	+/-0.00005 lb
11.0 lb	+/-0.0001 lb	0.0001 lb	+/-0.0001 lb
27.0 lb	+/-0.0005 lb	0.0005 lb	+/-0.0005 lb
55.0 lb	+/-0.001 lb	0.001 lb	+/-0.001 lb
75.0 lb	+/-0.002 lb	0.002 lb	+/-0.002 lb
110.0 lb	+/-0.002 lb	0.002 lb	+/-0.002 lb

CAPACITY	REPRODUCIBILITY	READABILITY	NON-LINEARITY
1000 g	+/-0.01 g	0.01 g	+/-0.01 g
2500 g	+/-0.02 g	0.02 g	+/-0.02 g
5000 g	+/-0.05 g	0.05 g	+/-0.05 g
12,500 g	+/-0.2 g	0.2 g	+/-0.2 g
25,000 g	+/-0.5 g	0.5 g	+/-0.5 g
34,000 g	+/-1.0 g	1.0 g	+/-1.0 g
50,000 g	+/-1.0 g	1.0 g	+/-1.0 g

Internal Counting Resolution: 1 Part in 500,000

Counting Accuracy: Selectable from 95% to 99.99%\*

Minimum Sample Size: Selectable from 1 to 999 pieces\*

Display Update Speed: Up to 5 times per second

Display Units: grams, ounces, pounds, troy ounces,  
pennyweights, carats

Counting Capacity: 999,999 pieces

\* Contact your authorized Setra dealer to change settings or refer to the *Setra Quick Count Technician's Guide*.

Data Communications: Bi-directional RS-232

Selectable Baud Rates\*: 300, 600, 1200,  
2400, 4800, 9600

Selectable Parity\*: even/odd/none

Display: 6-digit LCD

Pan: Stainless Steel

Operating Temperature: 40• to 110•F (5• to 43•C)

Power Supplied by AC Adaptor: Input - 110 VAC / 60 Hz  
Output - 16.5 VDC @ 500 ma

Platform/Pan Dimensions:

	1000 g (2.2 lb.)	5" diameter	130 mm
	2500 g (5.5 lb.)	5" diameter	130 mm
	5000 g (11 lb.)	6.25" diameter	160 mm
mm	12,500 g (27 lb.)	11" x 14"	280 mm x 355
mm	25,000 g (55 lb.)	11" x 14"	280 mm x 355
mm	34,000 g (75 lb.)	11" x 14"	280 mm x 355
mm	50,000 g (110 lb.)	11" x 14"	280 mm x 355

Overall Dimensions: All models: 14" w x 15.5" l x 6" h (feet retracted)  
360 mm x 395 mm x 145mm (feet retracted)

Shipping Weight: Quick Count - 1000g - 5000g: 26 lb. (12.0 Kg)  
Quick Count - 12,500g - 50,000g: 32 lb. (13.5 Kg)

Specifications subject to change without notice.

\* Contact your authorized Setra dealer to change settings or refer to the *Setra Quick Count Technician's Guide*.

## Appendix IX

# Setra Systems, Inc. Limited Two-Year Scale Warranty

Setra Systems, Inc. warrants the scales it manufactures to be free from defects in material and workmanship. Upon return, transportation charges prepaid, to Setra's factory within two (2) years of the date of purchase, Setra will repair or replace, at its option, any scale which it determines to contain defective material or workmanship and will return said scale to purchaser, transportation prepaid, at any point in the United States. Setra shall not be obligated, however, to repair or replace scales which have been repaired by unauthorized parties, abused, improperly installed, altered, or otherwise misused or damaged, even if by accident, in any way. Setra will not be responsible for any dismantling, reassembly or reinstallation charges.

Nothing in this warranty shall be construed as a warranty for merchantability or fitness for any specific use or purpose, and this warranty is in lieu of all other warranties, express or implied. Setra shall not be held liable under the terms of this warranty for any special, indirect, incidental or consequential damages claimed in connection with the scales' performance or availability.

Setra Systems, Inc.  
Weighing Systems Division  
159 Swanson Road • Boxborough, MA 01720 • (508) 263-1400

## Index

AC adaptor, 3, 11, 17, 20, 22  
accessories, 16  
accuracy, 4, 5, 6, 9, 10, 12, 13, 14, 21  
    enhancement, 5, 9  
Add nnn, 6  
Auto Count 200, 12, 15, 16, 20  
average piece weight, 5, 6, 9, 12, 14  
    update, 9  
bar code, 9, 12, 15, 16  
    wand, 15  
battery, 3, 6, 16  
    charging, 20  
    external charger, 20  
    installation, 19  
    portable operation, 20  
    replacement, 20  
baud rate, 11, 12, 14, 15, 16, 22  
bUSY, 5, 13, 17  
C nnn g, 4, 5  
cable, 15  
calibration, 13, 17  
    factory, 13  
    point, 13  
    span, 13  
capacity, 4, 5, 17, 21  
carats, 5, 7, 21  
**clear**, 4, 5, 8, 12, 17  
Clear To Send, 15  
computer, 4, 9, 11, 12, 14, 15, 18  
**count**, 5, 8, 9, 10  
default, 12, 15, 17, 18  
display, 1, 5, 7, 8, 22  
    flashing, 5  
    hysteresis, 14  
    hysteresis, 12  
    messages, 5  
    symbols, 5, 7  
    test, 4  
    update, 21  
d-noS, 17, 18  
draft, 3, 17  
full scale, 4  
grams, 4, 5, 7, 21  
handshaking, 15  
installation, 1, 15  
interface, 11, 15, 18  
keyboard, 1, 4, 5  
kitting, 6, 10, 14  
L xxxx, 13  
labels, 8  
LED, 6  
leveling, 3  
low bat, 6, 20  
memory, 17  
    battery backed, 17  
messages, 1, 17  
minimum accuracy, 6, 9, 10, 12  
minimum sample size, 9, 10, 12, 21  
model, 4, 22  
non-linearity, 21  
OFLO, 6  
OK, 5, 7, 9  
ounces, 5, 7, 21

pan, 3, 5, 22  
 parity, 11, 12, 14, 15, 22  
 PASS, 17  
 PC, 5  
 pennyweights, 5, 7, 21  
 peripheral device, 5, 14, 18  
 pounds, 5, 7, 21  
 precision, 14  
**print**, 5, 8, 11  
 print, 11, 12, 17  
 printer, 4, 5, 11  
     240P, 11, 12, 15, 16  
     340P, 11, 12, 15, 16  
 readability, 21  
 rEF n.n, 6, 12, 17  
 reproducibility, 14, 21  
 Request to Send, 15  
 reset, 17  
 resolution  
     internal counting, 21  
 reverse counting, 10  
 RS-232, 1, 5, 8, 11, 12, 15, 16, 17, 18, 22  
 sample, 7, 9, 12, 14  
**sample size**, 5, 8, 9, 10, 17  
     custom, 9  
 ScriptCoder, 11, 12, 15, 16  
 self-diagnostics, 4  
 serial port, 15  
 service, 17  
*Setra Quick Count Technician's Guide*, 1, 7, 9, 11, 12, 13, 15, 18, 21, 22  
 settings, 9, 12, 21  
     Printer, 12  
 setup information, 12, 17  
 software version number, 4, 6  
 specifications, 21  
 Sub nnn, 6, 10  
 troubleshooting, 17  
 troy ounces, 5, 7, 21  
 typographical conventions, 1  
 UnAbLE, 4, 5  
**units**, 5, 7, 21  
     disabling, 7  
 UPdAtE, 6, 9  
 vibration, 3, 17  
 wake up message, 4  
 warm up, 4, 12, 17  
 warranty, 18, 23  
 weighing, 7, 11, 12  
 zero, 4, 5, 7, 8, 9, 10, 17  
**zero**, 10

### **FCC WARNING**

This equipment has been tested and found to comply with the limits for a Class A digital device, pursuant to Part 15 of the FCC Rules. These limits are designed to provide reasonable protection against harmful interference when the equipment is operated in a commercial environment. This equipment generates, uses, and can radiate radio frequency energy and, if not installed and used in accordance with the instruction manual, may cause harmful interference to radio communications. Operation of this equipment in a residential area may cause harmful interference in which case the user will be required to correct the interference at their own expense.