

**FXi-09/HRA-09**

**Built-in  
Rechargeable Battery Unit**

**INSTRUCTION MANUAL**

**AND**

A&D Company, Limited



This is a hazard mark (caution mark).

© 2006 A&D Company, Limited

No part of this publication may be reproduced, transmitted, transcribed, or translated into any language in any form by any means without the written permission of A&D Company Ltd.

The contents of this manual and the specifications of the instrument covered by this manual are subject to change for improvement without notice.

# Warning Definitions

The warnings described in this manual have the following meanings:

## **Caution**

A potentially hazardous situation which, if not avoided, may result in minor or moderate injury. It may also be used to alert against unsafe practices.

## **Note**

An important description for proper use of the instrument.

# Precautions

When handling the balance with the rechargeable battery unit installed, observe the following precautions.

## **Caution**

- Do not place the unit in water, heat it, or disassemble it. It may build up heat, explode, or leak and cause a fire. Follow the local regulations when disposing of a used battery.
- Do not allow the unit to become wet. It may build up heat or cause a fire.
- Do not remove the battery panel and battery from the balance. It could short and build up heat or cause a fire.
- Recharge the battery only after the battery has been discharged completely. Charging the battery repeatedly, with incomplete discharging, may result in heat buildup, generating gases or leaking.
- When charging the battery, use the AC adapter provided with the balance. Using an AC adapter other than the one provided may cause heat buildup and could cause a fire.
- Keep the unit out of the reach of children.
- Do not drop or apply shock to the unit.

# Compliance

## **Compliance with FCC Rules**

Please note that this equipment generates, uses and can radiate radio frequency energy. This equipment has been tested and has been found to comply with the limits of Class A computing device pursuant to Subpart J of Part 15 of FCC rules. These rules are designed to provide reasonable protection against interference when the equipment is operated in a commercial environment. If this unit is operated in a residential area it may cause some interference and under these circumstances the user would be required to take, at his own expense, whatever measures are necessary to eliminate the interference. (FCC = Federal Communications Commission in the U.S.A.)

## **Compliance with EMC Directives**

 This device features radio interference suppression in compliance with valid EC Regulation 89/336/EEC.

The CE mark is an official mandatory European marking.

Please note that any electronic product must comply with local laws and regulations when sold or used anywhere outside Europe.

# Introduction

- The rechargeable battery unit (FX*i*-09, HRA-09) is exclusively designed for A&D-manufactured balances (of FX-*i* series, HR-A series). Using the battery unit, a balance can be operated in a location where an AC power source is not available.
- The battery unit consists of a battery panel and a built-in rechargeable battery that have been installed inside the balance prior to delivery.
- To install the battery unit into an balance that was not equipped with this option, contact your local A&D dealer.

## 1-1 Names

Balance rear view

Illustration using FX-*i* series as an example.

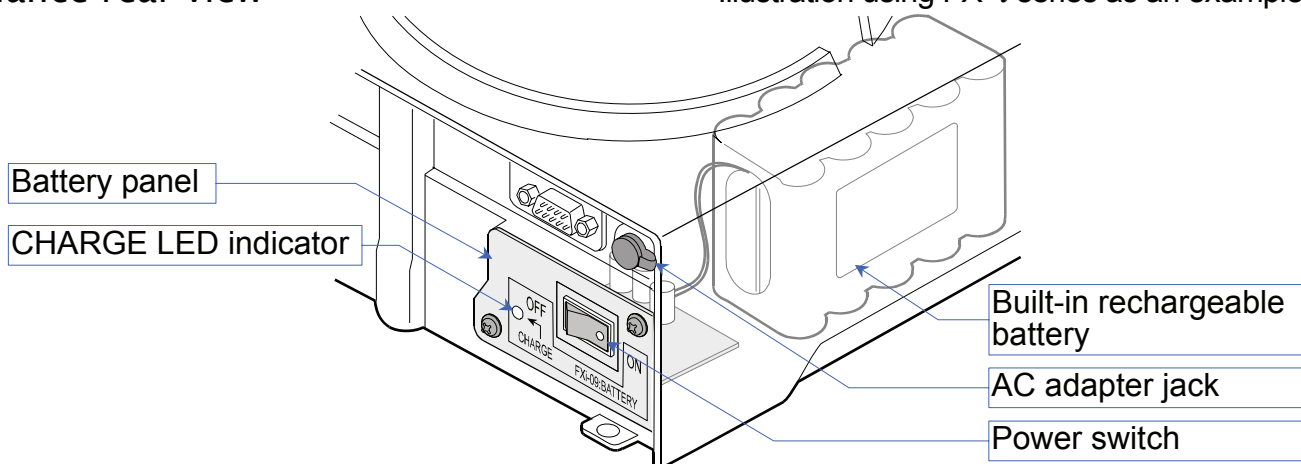

Balance front view

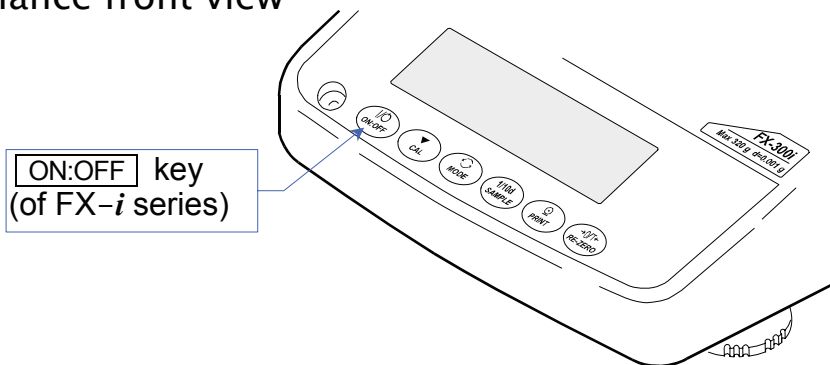

## Accessory

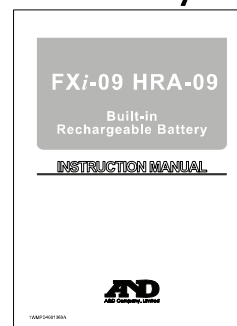

Instruction Manual  
(This document)

## 1-2 Specifications

- Mass of the battery unit ..... Approximately 0.4 kg
- Operating temperature range ..... +5 °C to +40 °C (+41 °F to +104 °F)
- Operating humidity range ..... 85%RH or less (No condensation)
- Charging time ..... Approximately 10 hours
- Charging method ..... Constant current charge with timer function for an automatic stop
- Battery type ..... Nickel-metal-hydride (Ni-MH) battery

### Operation hours

Balances*2	Operation Time Of The Battery*1
FX- <i>i</i> , FX- <i>i</i> WP*3, FX-CT, FX-GD series FZ- <i>i</i> , FZ- <i>i</i> WP*3, FZ-CT, FZ-GD series	Approximately 8 hours
HR-A, HR-AZ series	Approximately 14 hours

- \*1: Operation time of the battery depends on operating conditions.
- \*2: The FX*i*-02, FX*i*-08 and FX*i*-09 can not be used at the same time.  
In addition, the HRA-02, HRA-08 and HRA-09 can not be used at the same time.
- \*3: The battery unit is neither dust-tight nor waterproof. Therefore, upon installing the battery unit onto the FX-*i*WP and FZ-*i*WP series dust-tight and waterproof series, the balances will no longer comply with dust-tight and waterproof specifications.

### Notes For The Battery Unit

- Number of hours of continuous operation depend on operating condition.
- While charging, the balance can not be used.
- The battery may self-discharge while it is left unused for a long period of time. Charge the battery after a long period of non-use.
- Pressing the ON:OFF key only turns the display off. The balance, after the display is turned off using the ON:OFF key, is still consuming power. To turn the power off completely, disconnect the AC adapter from the balance and turn OFF the power switch that is located on the rear of the balance. (If the AC adapter is connected to the balance under this condition, the battery will start charging.)
- Every time the power switch on the rear of the balance is turned OFF with the AC adapter connected to the balance, the battery will start charging. Charging the battery before it is completely discharged will shorten the battery life.

## 1-3 Battery Condition And Operation

Below is a list of battery operations according to the combination of the power switch and AC adapter conditions. For details, read each section on the following pages.

Operation	Power switch	AC adapter	Description
Charging the battery	OFF	Connected	The CHARGER LED indicator blinks and charging starts. After about 10 hours, charging stops automatically and the CHARGER LED indicator goes out. Charge the battery after it is completely discharged. While the charging, the balance can not be used.
Using the balance powered by the battery	ON	Not connected	The battery supplies power to the balance. Refer to the specifications for operation time of the battery.
None	OFF	Not connected	The battery is not used.
Using the balance powered by the AC adapter	ON	Connected	The AC adapter supplies power to the balance. The AC adapter does not charge the battery.

# Charging the Battery

## Note

- Charging the battery before it is completely discharged will shorten the battery life.
- Charge the battery fully until the CHARGE LED indicator goes out. This procedure will take about 10 hours.
- During the charging operation, the balance can not be used.

## Procedure:

1. Make sure that the battery is completely discharged before recharging.

How to determine when the battery is completely discharged:

- When the power switch on the rear of the balance is turned ON without the AC adapter connected, the balance does not operate or the balance displays "L b" (Low battery).

2. Turn the power switch on the rear of the balance OFF.

3. Connect the AC adapter to the balance. The battery will start charging. The CHARGE LED indicator will blink during the charging operation.

4. Charging will take about 10 hours. Be sure to fully charge until the CHARGE LED indicator goes out.

5. After charging is complete, disconnect the AC adapter from the balance to avoid recharging.

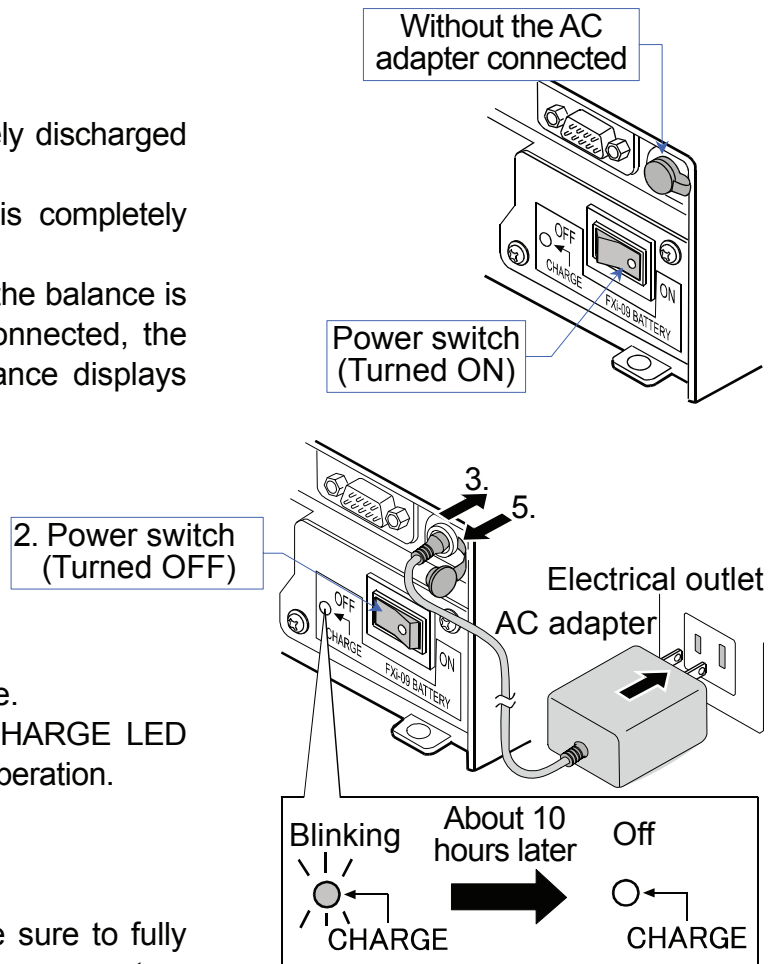

Illustration using FX-*i* series as an example.

# Using the Balance Powered by the Battery

- Use the battery to supply power to the balance as follows:

## Procedure:

1. After charging is complete, disconnect the AC adapter from the balance.
2. Turn the power switch on the rear of the balance ON. The battery will start supplying power to the balance.
3. When the balance is not to be used, turn the power switch on the rear of the balance OFF. Under this condition, the battery is not used.

## Note

When the power switch is turned OFF with the AC adapter connected to the balance, the battery will start charging.

4. While the balance is in use, if the remaining charge decreases and the voltage drops, the balance displays "Lb" or becomes completely inactive. Under such conditions, stop using the balance immediately and charge the battery as described on page 4.

## Note

When the balance displays "Lb" or becomes completely inactive, be sure to keep the power switch turned OFF to protect the battery.

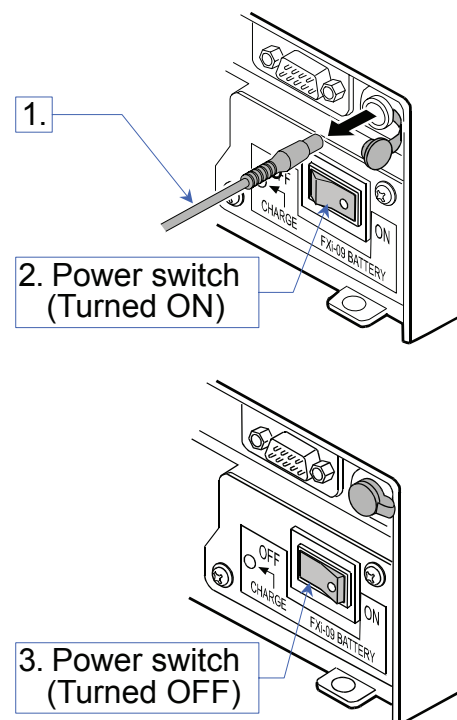

Illustration using FX-*i* series as an example.

# Using the Balance Powered by the AC Adapter

Use the AC adapter to supply power to the balance as follows:

- The balance can be used powered by the AC adapter even if the battery is depleted.
- While the balance is used powered by the AC adapter, the battery is not used and charging is not performed.

## Procedure:

1. Turn the power switch on the rear of the balance ON.

### Note

Be sure to turn the power switch ON. If the power switch is turned OFF and the AC adapter is connected to the balance, the battery will start charging.

2. Connect the AC adapter to the balance.  
The AC adapter starts to supply power to the balance.

### Note

When the AC adapter is not connected, the battery supplies power to the balance.

3. When the balance is not to be used, disconnect the AC adapter from the balance and turn the power switch on the rear of the balance OFF. Under this condition, the battery is not used.

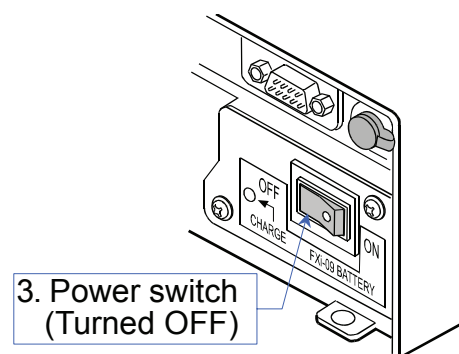
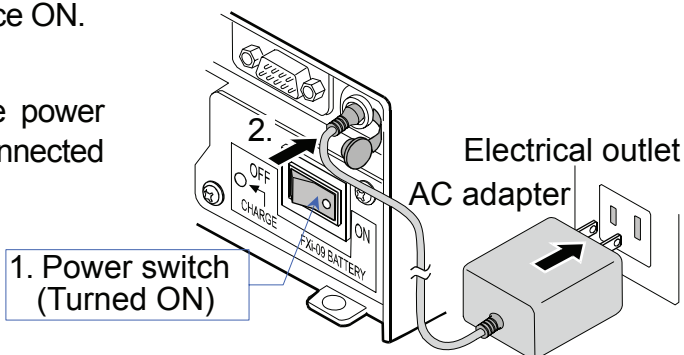

Illustration using FX-*i* series as an example.











**A&D Company, Limited**

3-23-14 Higashi-Ikebukuro, Toshima-ku, Tokyo 170-0013 JAPAN  
Telephone: [81] (3) 5391-6132 Fax: [81] (3) 5391-6148

**A&D ENGINEERING, INC.**

1756 Automation Parkway, San Jose, California 95131 U.S.A.  
Telephone: [1] (408) 263-5333 Fax: [1] (408)263-0119

**A&D INSTRUMENTS LIMITED <UK Office>**

Unit 24/26 Blacklands Way, Abingdon Business Park, Abingdon, Oxfordshire OX14 1DY  
Telephone: [44] (1235) 550420 Fax: [44] (1235) 550485

**A&D INSTRUMENTS LIMITED <German Sales Office>**

Große Straße 13 b 22926 Ahrensburg Deutschland  
Telefon: [49] (0) 4102 459230 Telefax: [49] (0) 4102 459231

**A&D Australasia Pty Ltd.**

32 Dew Street, Thebarton, South Australia 5031 AUSTRALIA  
Telephone: [61] (8) 8301-8100 Fax: [61] (8) 8352-7409

**A&D KOREA Limited**

한국에이.엔.디(주)  
대한민국 서울시 영등포구 여의도동 36-2 맨하탄 빌딩 8층  
( 8th Floor, Manhattan Bldg. 36-2 Yoido-dong, Youngdeungpo-ku, Seoul, KOREA )  
전화: [82] (2) 780-4101 팩스: [82] (2) 782-4280

**A&D RUS CO., LTD.**

Компания Эй энд Ди Рус  
121357, Российская Федерация, г.Москва, ул. Вереysкая, дом 17  
( Bldg. 17, Vereyskaya st., Moscow, 121357 RUSSIAN FEDERATION )  
тел.: [7] (495) 937-33-44 факс: [7] (495) 937-55-66

**A&D Instruments India Private Limited**

ऐ&डी इन्स्ट्रूमेन्ट्स इण्डिया प्रा० लिमिटेड  
509, उद्योग विहार , फेस -5, गुडगांव - 122016, हरियाणा , भारत  
( 509, Udyog Vihar, Phase-V, Gurgaon - 122 016, Haryana, India )  
फोन : 91-124-4715555 फैक्स : 91-124-4715599