



*Adam Equipment*

## **MDW-160M**

**MECHANICAL PHYSICIAN SCALE**

(P.N. 4283, Revision B2, December 2006)



## CONTENTS

1. INTRODUCTION.....	3
2. SPECIFICATIONS .....	3
3. INSTALLATION.....	4
3.1 GENERAL INSTALLATION.....	4
3.2 HEIGHT ROD INSTALLATION .....	6
4. MEASURING HEIGHT .....	6
5. WEIGHING OPERATION .....	8



## 1. INTRODUCTION

- The Medical Physician Scale MDW-160M can weigh a person as well as measure the height.
- It is simple to use and can be moved around with the help of the wheel attachment at the bottom of the scale.
- The MDW-160M scale is widely applicable for use in business, schools, hospitals, clinics and sports departments.
- A height rod assembly is included as standard.

## 2. SPECIFICATIONS

	<b>MDW-160M</b>
Capacity	160 kg / 350 lb.
Readability	100 g / 0.2 lb.
Platform Size	375 mm x 275 mm / 14.8" x 10.8"
Overall dimension	530 mm x 275 mm x 1485 mm / 20.9" x 10.8" x 58.5"
Height measurement	Up to 210 cm / 84"
Division of height measurement	0.5 cm / 0.2"
Gross weight	18 kg / 40 lb

## 3. INSTALLATION

### 3.1 GENERAL INSTALLATION

This precision instrument is extremely easy to set up, as all major parts are factory pre-assembled.

#### Hardware supplied for installation:

- 6 no. M6 x 12 screws
- 6 no. M6 Lock washers
- 2 no. Hex Head screws
- Tool (Spanner/Wrench)

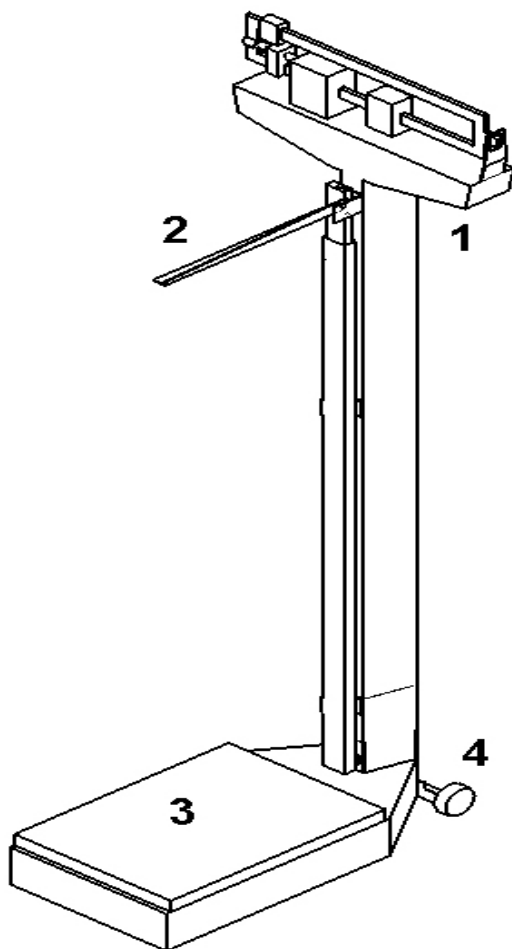

- |  |
|--|
| <ol style="list-style-type: none"><li>1. Column with head</li><li>2. Height measuring rod</li><li>3. Platform base</li><li>4. Wheel attachment</li></ol> |
|--|

**NOTE:** If the column bracket is bent, straighten it before assembling.

Slip the column over the column bracket on the base.

Hold the column straight so that the draft rod fits into the opening aperture of the column bracket.

Fix the column to the column bracket using two M6 screws in front of the column and four at the back.

Lay down the scale, with column horizontal to the floor.

Raise the draft rod keeping out of the lever's way.

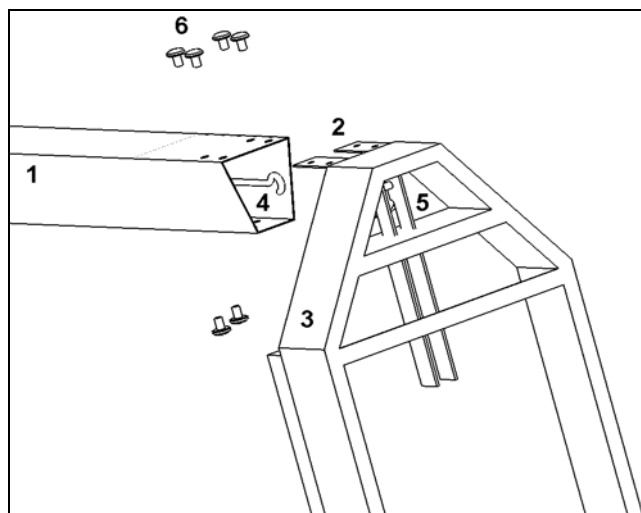

1. Column
2. Column bracket
3. Base
4. Hook at the end of the Draft rod
5. Lever with pivot
6. M6 screws

Push the lever. When the lever is in position, hook the draft rod around the pivot.

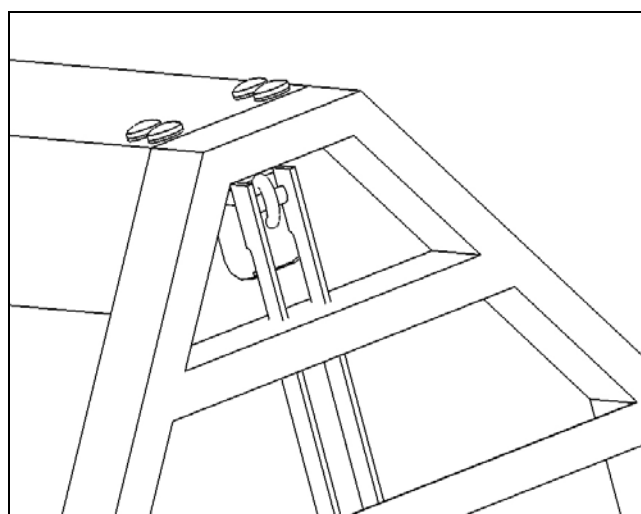

← An assembled view

### 3.2 HEIGHT ROD INSTALLATION

- Insert the two hexagonal headed screws from the hardware pack into the holes in the front of the column and tighten slightly.
- Place both the height rod clamping brackets over the two pre-installed hexagonal headed screws and pull it down.
- Use the included wrench to tighten both the screws. Do not over tighten the screws.

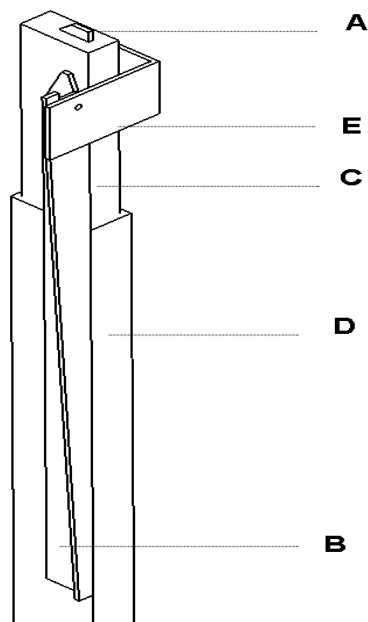

**A.** Latch to lock/unlock the measuring arm

**B.** The measuring arm

**C.** The inner height rod

**D.** The outer height rod

**E.** Two height rod clamping brackets for fixing the height rods assembly to the column. One hexagonal headed screw is required for each bracket.

## 4. MEASURING HEIGHT

### Preparing the scale to measure the height-

- Before the person steps onto the scale platform, the measuring arm should be lifted to the horizontal position, and raised well above the person's apparent height.
- The person may now step onto the scale platform.



- The measuring arm should be held horizontal and above the person's head and should not be released.
- Carefully lower the measuring arm, while keeping it horizontal, until it rests gently upon the top of the person's head. If the person is shorter than 101.5 cm, push the latch to the right, while simultaneously pushing down the measuring arm until it rests horizontally upon the top of the person's head.

**Read the height of the person as follows:**

- The rear end of the measuring arm is tapered to point at the reading on the height rods.
- If the tapered end of the measuring arm points at the outer height rod, then the height of the person is same as the reading at this point on the outer height rod.
- If the tapered end of the measuring arm points at the inner height rod, then the correct height of the person is same as the reading shown on the inner height rod where both the height rod meets, i.e., read at the top of the outer height rod (Just above the "Read" arrow marked on the outer height rod).
- While holding the measuring arm horizontally, raise the arm above the person's head. The person may now step off the scale platform. Hold the arm horizontal until the person is clear of the height rod.
- Fold the measuring arm back to the vertical position and adjust the height rod back to the rest position (i.e. the measuring arm should be locked in place within the inner height rod and the inner rod should be at its lowest position).

## 5. WEIGHING OPERATION

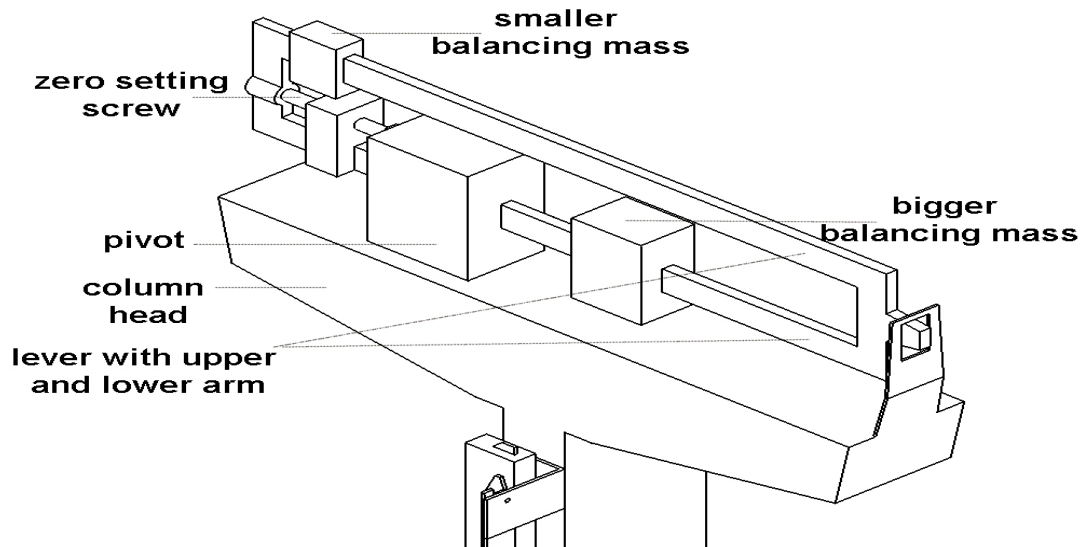

### To do the zero setting-

- For accurate weighing, place the scale on a levelled floor.
- Move both the balancing masses to zero when the scale platform is empty.
- If the scale is balanced, the lever will be in the horizontal position. This will be indicated by the arrow indicator being in line with the horizontal mark on the right side of the column head.
- It may be necessary to turn the zero-setting screw to the right or left until the scale balances.

## To weigh a person-

- The person to be weighed can now step onto the scale platform.
- The lever will move away from its original position.
- Move the balancing masses along the calibrated lever arms to return the lever to the horizontal position.
- For this the bigger balancing mass should be moved first and then the smaller one for finer adjustment.
- **NOTE:** While moving the lower (larger) balancing mass along the lower arm of the lever, make sure that it sits in one of the notches properly. In that case, its upper pointer will be in line with one of the markings of the lower arm of the lever. The reading at this marking will indicate the weight of the person using the larger balancing mass.
- The upper (smaller) balancing mass is now moved along the upper arm of the lever till the lever returns to its original horizontal position. This is to obtain the finer weight. The reading at this point is noted.
- The total reading of the two balancing masses will give the final weight of the person on the platform.

For example,

Lower mass 60 kg + Upper mass 2.5 kg  
= Total weight of the person is 62.5 kg.

**ADAM EQUIPMENT** is an ISO 9001:2000 certified global organisation with more than 30 years experience in the production and sale of electronic weighing equipment. Products are sold through a world wide distributor network supported from our company locations in the UK, USA and SOUTH AFRICA.

**ADAM's** products are predominantly designed for the Laboratory, Educational, Medical and Industrial Segments. The product range is as follows:

- Analytical and Precision Laboratory Balances
- Top Loading Scales for Educational establishments
- Counting Scales for Industrial and Warehouse applications
- Digital Weighing/Check-weighing Scales
- High performance Platform Scales with extensive software features including parts counting, percent weighing etc.
- Crane scales for heavy-duty industrial weighing
- Digital Electronic Scales for Medical use
- Retail Scales

<p><b>Adam Equipment Co. Ltd.</b> Bond Avenue Milton Keynes MK1 1SW UK</p> <p>Phone:+44 (0)1908 274545 Fax: +44 (0)1908 641339</p> <p>e-mail: <a href="mailto:sales@adamequipment.co.uk">sales@adamequipment.co.uk</a></p>	<p><b>Adam Equipment Inc.</b> 26, Commerce Drive Danbury, CT 06810 USA</p> <p>Phone: +1 203 790 4774 Fax: +1 203 792 3406</p> <p>e-mail: <a href="mailto:sales@adamequipment.com">sales@adamequipment.com</a></p>	<p><b>Adam Equipment S.A. (Pty) Ltd.</b> P.O. Box 1422 Kempton Park 1620 Johannesburg Republic of South Africa</p> <p>Phone +27 (0)11 974 9745 Fax: +27 (0)11 392 2587</p> <p>e-mail: <a href="mailto:sales@adamequipment.co.za">sales@adamequipment.co.za</a></p>
--	---	--

© Copyright by Adam Equipment Co. Ltd. All rights reserved. No part of this publication may be reprinted or translated in any form or by any means without the prior permission of Adam Equipment.

Adam Equipment reserves the right to make changes to the technology, features, specifications and design of the equipment without notice.

All information contained within this publication is to the best of our knowledge timely, complete and accurate when issued. However, we are not responsible for misinterpretations which may result from the reading of this material.

The latest version of this publication can be found on our Website.

Visit us at [www.adamequipment.com](http://www.adamequipment.com)